

dal 1968



SCAMBIATORI - BOLLITORI - SERBATOI



BTEH



ENAMELLED STEEL DHW CALORIFIER EQUIPPED WITH
ONE REMOVABLE SPIRAL FINNED COPPER COIL

ENAMELLED STEEL DHW CALORIFIER WITH ONE REMOVABLE SPIRAL FINNED COPPER COIL

Calorifiers made of enamelled steel with one removable spiral finned copper coil for production and storage of DHW. Designed for connection to a single primary energy source.

The calorifiers of the **BTEH** are available from 200 to 2000 L as standard; size and number of coils can be increased upon request.

They are available, in the larger sizes, in vertical-low height version to allow them to be installed in rooms where the available height is not sufficient for the standard design.

The BTEH series calorifiers are equipped with spiral finned copper coils that significantly increase the heat exchange surface area relative to the space occupied, resulting in higher thermal efficiency.

The possibility of selecting between various operating pressures - up to 10 bar - and the availability of different external claddings for indoor or outdoor installation, extends their use to all the possible applications.

Protection from galvanic currents is provided by the electronic anodes fitted as standard, which both save on costs of checking and replacing conventional magnesium anodes and ensure superior reliability and durability.

CONSTRUCTIONS

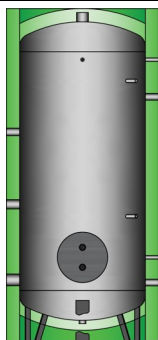

BTEH

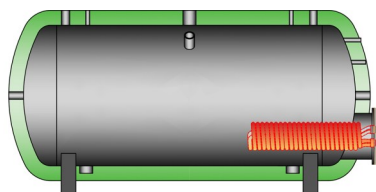

BTEH-O

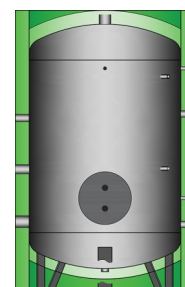

BTEH-R

	BTEH	BTEH-O	BTEH-R
TANK MATERIAL	Carbon steel	Carbon steel	Carbon steel
INTERNAL SURFACE TREATMENT	CERAMFLON enamel	CERAMFLON enamel	CERAMFLON enamel
EXTERNAL SURFACE TREATMENT	Anti-rust primer	Anti-rust primer	Anti-rust primer
CAPACITY	200 ÷ 2000 L	200 ÷ 2000 L	1500 ÷ 2000 L
VERSION	Vertical	Horizontal	Vertical LOW-height
CONNECTIONS	Threaded	Threaded	Threaded
PRIMARY CHEST MATERIAL	CERAMFLON enamelled steel	CERAMFLON enamelled steel	CERAMFLON enamelled steel
REMOVABLE SPIRAL FINNED COIL MATERIAL	COPPER	COPPER	COPPER
INSULATION 200 ÷ 500 L	Hard foam Polyurethane 80 mm injected	Hard foam Polyurethane 80 mm injected	—
INSULATION 800 ÷ 2000 L	PLFH 100 mm High density eco-friendly polyester fiber	PLFH 100 mm High density eco-friendly polyester fiber	PLFH 100 mm High density eco-friendly polyester fiber
CLADDING	<ul style="list-style-type: none"> • PVC Yellow RAL1023 • Aluminium 	<ul style="list-style-type: none"> • PVC Yellow RAL1023 • Aluminium 	<ul style="list-style-type: none"> • PVC Yellow RAL1023 • Aluminium
ANODE (factory fitted)	Electronic	Electronic	Electronic
ACCESSORIES (factory fitted)	Thermometer	Thermometer	Thermometer

Energy efficiency class - Regulation EU 812/2013 & 814/2013 (European Directive 2009/125/CE)

		Capacity	200	300	500	800	1000	1500	2000
	Energy efficiency class		B	B	B	C	C	C	C
BTEH	Standing loss	S W	55	64	81	133	143	167	189
	Storage volume	V L	193	294	503	793	917	1482	1987
	Energy efficiency class							C	C
BTEH-R	Standing loss	S W						166	185
	Storage volume	V L						1520	1961

STANDARD WORKING CONDITIONS

		Capacity	200	300	500	800	1000	1500	2000
Tank working pressure	bar	ATM ÷ 8	ATM ÷ 8	ATM ÷ 8	ATM ÷ 8	ATM ÷ 8	ATM ÷ 8	ATM ÷ 6	ATM ÷ 6
Tank working temperature	°C	AMB ÷ 85	AMB ÷ 85	AMB ÷ 85	AMB ÷ 85	AMB ÷ 85	AMB ÷ 85	AMB ÷ 85	AMB ÷ 85
Heat exchangers working pressure	bar	ATM ÷ 12	ATM ÷ 12	ATM ÷ 12	ATM ÷ 12	ATM ÷ 12	ATM ÷ 12	ATM ÷ 12	ATM ÷ 12
Heat exchangers working temperature	°C	AMB ÷ 99	AMB ÷ 99	AMB ÷ 99	AMB ÷ 99	AMB ÷ 99	AMB ÷ 99	AMB ÷ 99	AMB ÷ 99

REGULATORY COMPLIANCE

ErP - Reg. 812/2013 e Reg. 814/2013 | CE

European Pressure Equipment Directive (PED) 2014/68/UE | SEP (Sound Engineering Practice) - exclusion from CE marking - Art. 4.3

D.M. 174/04 or Reg. (CE) 1935/04 | Compatible with potable water

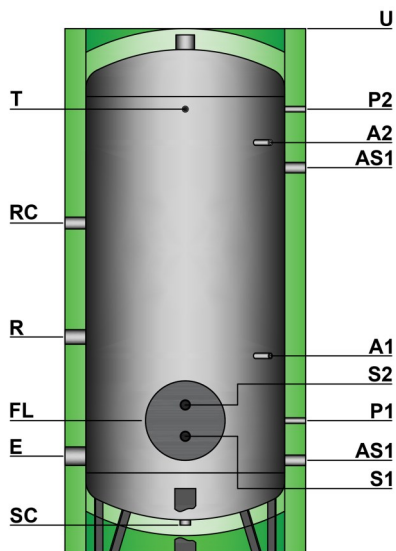

INSTALLATION ASSUMPTIONS

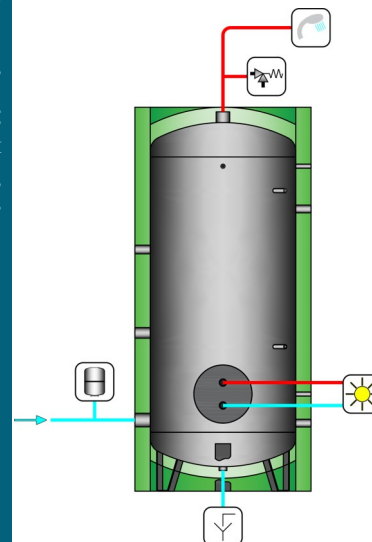

The proposed diagrams are for illustration purposes only.

BTEH GENERAL CHARACTERISTICS

	Capacity - L	200	300	500	800	1000	1500	2000
DIMENSIONS								
Diameter without insulation	mm	450	550	650	800	800	950	1100
Diameter with insulation	mm	610	710	810	1000	1000	1150	1300
Overall height	mm	1513	1554	1844	1950	2200	2510	2535
Overturning height with without insulation	mm	1613 —	1709 —	2014 —	2080 1918	2316 2166	2653 2502	2712 2541

CONNECTIONS

E Cold water supply	mm Ø	353 1"½	369 1"½	384 1"½	420 2"	420 2"	465 2"½	485 2"½
U DHW return	mm Ø	1513 1"½	1554 1"½	1844 1"½	1950 2"	2200 2"	2510 2"½	2535 2"½
RC Recirculation	mm Ø	1003 1"½	1019 1"½	1259 1"½	1370 1"½	1405 1"½	1580 1"½	1600 1"½
R Immersion electric heater	mm Ø	773 2"	789 2"	804 2"	1010 2"	1010 2"	1035 2"	1055 2"
P1 Sensor	mm Ø	473 ½"	489 ½"	504 ½"	610 ½"	608 ½"	635 ½"	655 ½"
P2 Sensor	mm Ø	1253 ½"	1269 ½"	1534 ½"	1550 ½"	1698 ½"	2125 ½"	2095 ½"
T Thermometer	mm Ø	1253 ½"	1269 ½"	1534 ½"	1550 ½"	1800 ½"	2125 ½"	2095 ½"
A1 Anode	mm Ø	853 ½"	869 ½"	884 ½"	920 ½"	608 ½"	945 ½"	965 ½"
A2 Anode	mm Ø	—	—	—	—	—	1965 ½"	1935 ½"
AS1 Spare	mm Ø	353 1"¼	369 1"¼	384 1"¼	420 1"¼	418 1"¼	445 1"¼	465 1"¼
AS2 Spare	mm Ø	1153 1"¼	1169 1"¼	1184 1"¼	1220 1"¼	1818 1"¼	1845 1"¼	1865 1"¼
FL Heat Exchanger manhole	mm	473	489	504	610	610	635	655
	Ø	220×300	220×300	220×300	300×380	300×380	300×380	300×380
S1 Heat exchanger return	mm Ø	438 ¾"M	454 ¾"M	469 ¾"M	575 ¾"M	565 1"¼M	590 1"¼M	610 1"¼M
S2 Heat exchanger supply	mm Ø	508 ¾"M	524 ¾"M	539 ¾"M	645 ¾"M	655 1"¼M	725 1"¼M	700 1"¼M
SC Drain	mm Ø	118 1"¼	109 1"¼	99 1"¼	95 1"¼	95 1"¼	135 1"¼	123 1"¼

PERFORMANCES

Heat exchanger heating surface area	m ²	0,76	1,58	2,27	3,17	3,60	4,54	5,26
HEX power (Prim. 80/55°C - Sec. 10/45°C)	kW	25	41	47	52	59	73	81
DHW production 10/45°C	L/h	602	1011	1156	1276	1445	1794	1999

EMPTY WEIGHTS

Empty weight	kg	55	65	95	130	145	205	265
--------------	----	----	----	----	-----	-----	-----	-----

Note: All the measurements of the connections are considered "from the ground". The thread are female GAS type, unless otherwise specified. The tanks higher than 2200mm are packaged horizontally.

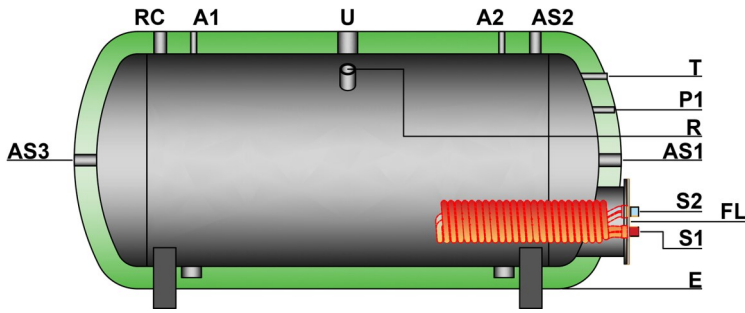

INSTALLATION ASSUMPTIONS

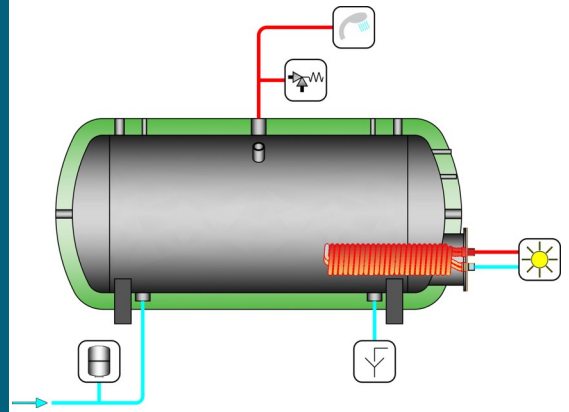

The proposed diagrams are for illustration purposes only.

BTEH-O GENERAL CHARACTERISTICS

	Capacity	200	300	500	800	1000	1500	2000
DIMENSIONS								
Diameter without insulation	mm	450	550	650	800	800	950	1100
Diameter with insulation	mm	550	650	750	1000	1000	1150	1300
Overall height	mm	656	755	855	1091	1091	1254	1395
Overturning height with without insulation	mm	1469	1519	1819	2049	2299	2559	2587
CONNECTIONS								
E Cold water supply	mm Ø	106 1 1/2"	105 1 1/2"	105 1 1/2"	121 2"	121 2"	154 2 1/2"	145 2 1/2"
U DHW return	mm Ø	656 1 1/2"	755 1 1/2"	855 1 1/2"	1091 2"	1091 2"	1254 2 1/2"	1395 2 1/2"
RC Recirculation	mm Ø	656 1 1/2"	755 1 1/2"	855 1 1/2"	1091 1 1/4"	1091 1 1/4"	1254 1 1/2"	1395 1 1/2"
R Immersion electric heater	mm Ø	575 2"	660 2"	745 2"	945 2"	945 2"	1085 2"	1204 2"
P1 Sensor	mm Ø	486 1/2"	548 1/2"	609 1/2"	831 1/2"	831 1/2"	904 1/2"	1135 1/2"
T Thermometer	mm Ø	576 1/2"	655 1/2"	727 1/2"	931 1/2"	931 1/2"	1054 1/2"	1235 1/2"
A1 Anode	mm Ø	656 1/2"	755 1/2"	855 1/2"	1091 1/2"	1091 1/2"	1254 1/2"	1395 1/2"
A2 Anode	mm Ø	—	—	—	—	—	1254 1/2"	1395 1/2"
AS1 Spare	mm Ø	—	—	—	591 1 1/2"	591 1 1/2"	679 1 1/2"	745 1 1/2"
AS2 Spare	mm Ø	656 1 1/4"	755 1 1/4"	855 1 1/4"	1091 1 1/4"	1091 1 1/4"	1254 1 1/4"	1395 1 1/4"
AS3 Spare	mm Ø	381 1 1/4"	430 1 1/4"	480 1 1/4"	591 1 1/4"	591 1 1/4"	679 1 1/4"	745 1 1/4"
FL Heat exchanger manhole	mm	296	300	280	351	351	404	445
	Ø mm	220×300	220×300	220×300	300×380	300×380	300×380	300×380
S1 Heat exchanger return	mm Ø	261 3/4"M	265 3/4"M	245 3/4"M	316 3/4"M	316 1 1/4"M	369 1 1/4"M	410 1 1/4"M
S2 Heat exchanger supply	mm Ø	331 3/4"M	335 3/4"M	315 3/4"M	386 3/4"M	386 1 1/4"M	439 1 1/4"M	480 1 1/4"M

PERFORMANCES

Heat exchanger heating surface area	m ²	0,76	1,58	2,27	3,17	3,60	4,54	5,26
HEX power (Prim. 80/55°C - Sec. 10/45°C)	kW	25	41	47	52	59	73	81
DHW production 10/45°C	L/h	602	1011	1156	1276	1445	1794	1999

EMPTY WEIGHTS

Empty weight	kg	59	77	104	140	159	233	300
--------------	----	----	----	-----	-----	-----	-----	-----

Note: All the measurements of the connections are considered "from the ground". The thread are female GAS type, unless otherwise specified. The tanks higher than 2200mm are packaged horizontally.

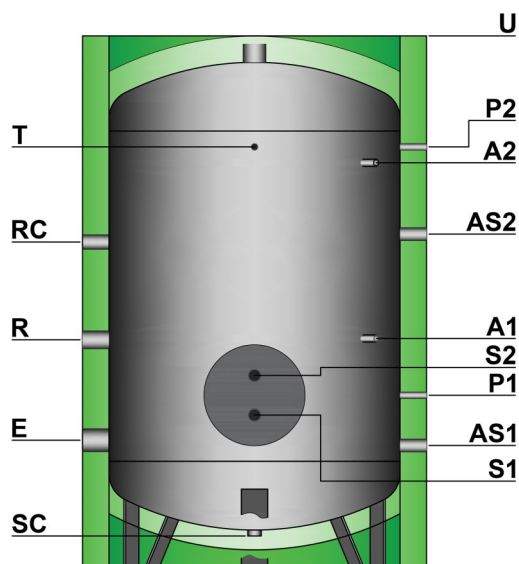

INSTALLATION ASSUMPTIONS

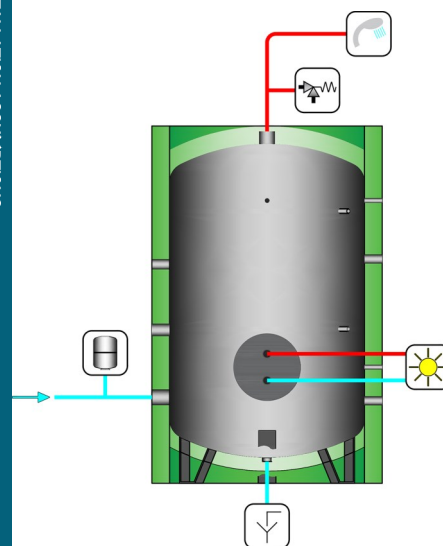

The proposed diagrams are for illustration purposes only.

BTEH-R GENERAL CHARACTERISTICS

	Capacity	1500	2000
DIMENSIONS			
Diameter without insulation	mm	1100	1250
Diameter with insulation	mm	1300	1450
Overall height	mm	2015	2039
Overturning height with without insulation	mm	2237 2019	2310 2059
CONNECTIONS			
E Cold water supply	mm Ø	485 2"½	504 2"½
U DHW return	mm Ø	2015 2"½	2039 2"½
RC Recirculation	mm Ø	1235 1"½	1254 1"½
R Immersion electric heater	mm Ø	865 2"	884 2"
P1 Sensor	mm Ø	655 ½"	674 ½"
P2 Sensor	mm Ø	1595 ½"	1564 ½"
T Thermometer	mm Ø	1595 ½"	1564 ½"
A1 Anode	mm Ø	870 ½"	864 ½"
A2 Anode	mm Ø	1535 ½"	1504 ½"
AS1 Spare	mm Ø	465 1"¼	484 1"¼
AS2 Spare	mm Ø	1265 1"¼	1284 1"¼
FL Heat exchanger manhole	mm Ø	655 300×380	674 300×380
S1 Heat exchanger return	mm Ø	610 1"¼M	629 1"¼M
S2 Heat exchanger supply	mm Ø	700 1"¼M	719 1"¼M
SC Drain	mm Ø	123 1"¼	106 1"¼
PERFORMANCES			
Heat exchanger heating surface area	m²	4,54	5,26
HEX power (Prim. 80/55°C - Sec. 10/45°C)	kW	73	81
DHW production 10/45°C	L/h	1794	1999
EMPTY WEIGHTS			
Empty weight	kg	248	315

Note: All the measurements of the connections are considered "from the ground". The thread are female GAS type, unless otherwise specified. The tanks higher than 2200mm are packaged horizontally.



BTEH - SPIRAL FINNED COPPER COIL HEAT EXCHANGER PERFORMANCES

Primary (80-55)°C | Secondary (10-45)°C

Storage Capacity	Heating Surface area	Capacity	Primary Flow	SECONDARY SIDE		
				Continuous production	Production first 10'	Production first 60'
<i>L</i>	<i>m²</i>	<i>kW</i>	<i>L/h</i>	<i>L/h</i>	<i>L</i>	<i>L</i>
200	0,76	25	843	602	300	802
300	1,58	41	1416	1011	469	1311
500	2,27	47	1618	1156	693	1656
800	3,17	52	1787	1276	1013	2076
1000	3,60	59	2023	1445	1241	2445
1500	4,54	73	2512	1794	1799	3294
2000	5,26	81	2798	1999	2333	3999

Primary (70-50)°C | Secondary (10-45)°C

Storage Capacity	Heating Surface area	Capacity	Primary Flow	SECONDARY SIDE		
				Continuous production	Production first 10'	Production first 60'
<i>L</i>	<i>m²</i>	<i>kW</i>	<i>L/h</i>	<i>L/h</i>	<i>L</i>	<i>L</i>
200	0,76	18	759	433	272	633
300	1,58	32	1373	784	431	1084
500	2,27	37	1589	908	651	1408
800	3,17	41	1770	1011	969	1811
1000	3,60	47	2023	1156	1193	2156
1500	4,54	59	2546	1455	1743	2955
2000	5,26	66	2853	1631	2272	3631

Primary (60-45)°C | Secondary (10-45)°C

Storage Capacity	Heating Surface area	Capacity	Primary Flow	SECONDARY SIDE		
				Continuous production	Production first 10'	Production first 60'
<i>L</i>	<i>m²</i>	<i>kW</i>	<i>L/h</i>	<i>L/h</i>	<i>L</i>	<i>L</i>
200	0,76	11	642	275	246	475
300	1,58	23	1324	568	395	868
500	2,27	27	1565	671	612	1171
800	3,17	31	1766	757	926	1557
1000	3,60	36	2047	877	1146	1877
1500	4,54	46	2629	1127	1688	2627
2000	5,26	52	2970	1273	2212	3273

BTEH - SPIRAL FINNED COPPER COIL HEAT EXCHANGER PRESSURE DROP

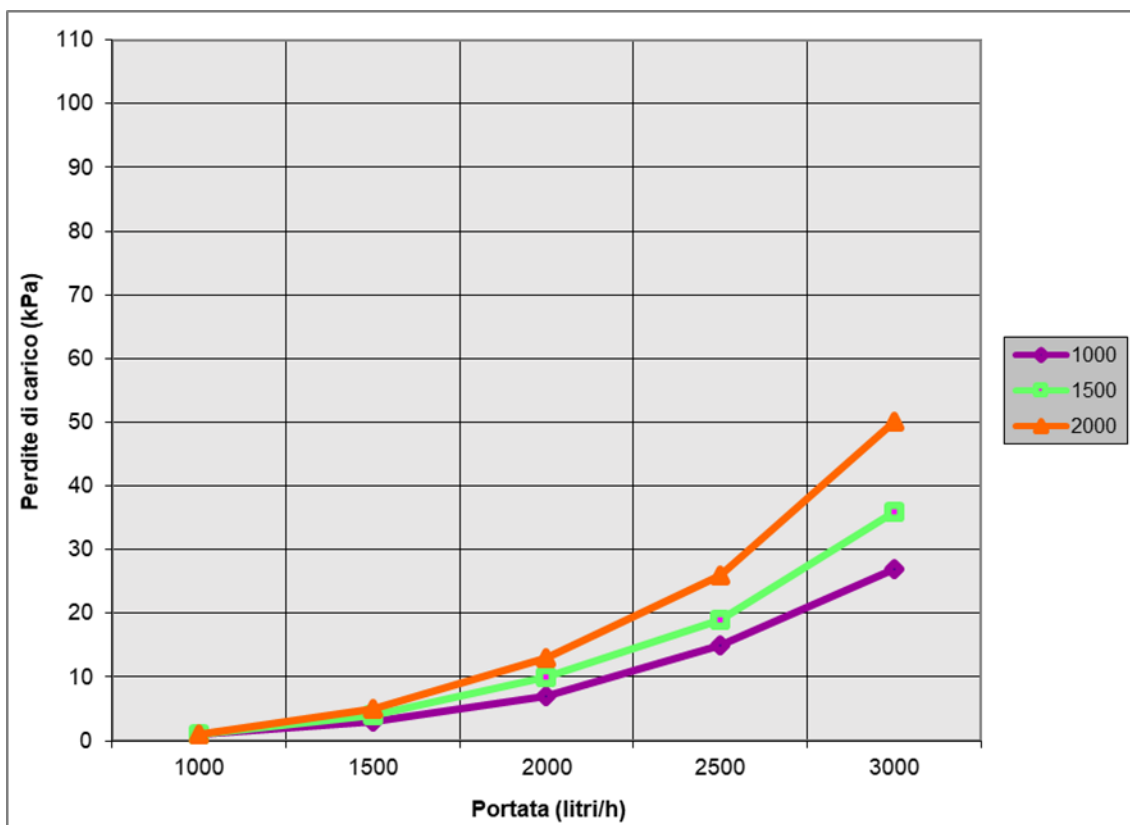
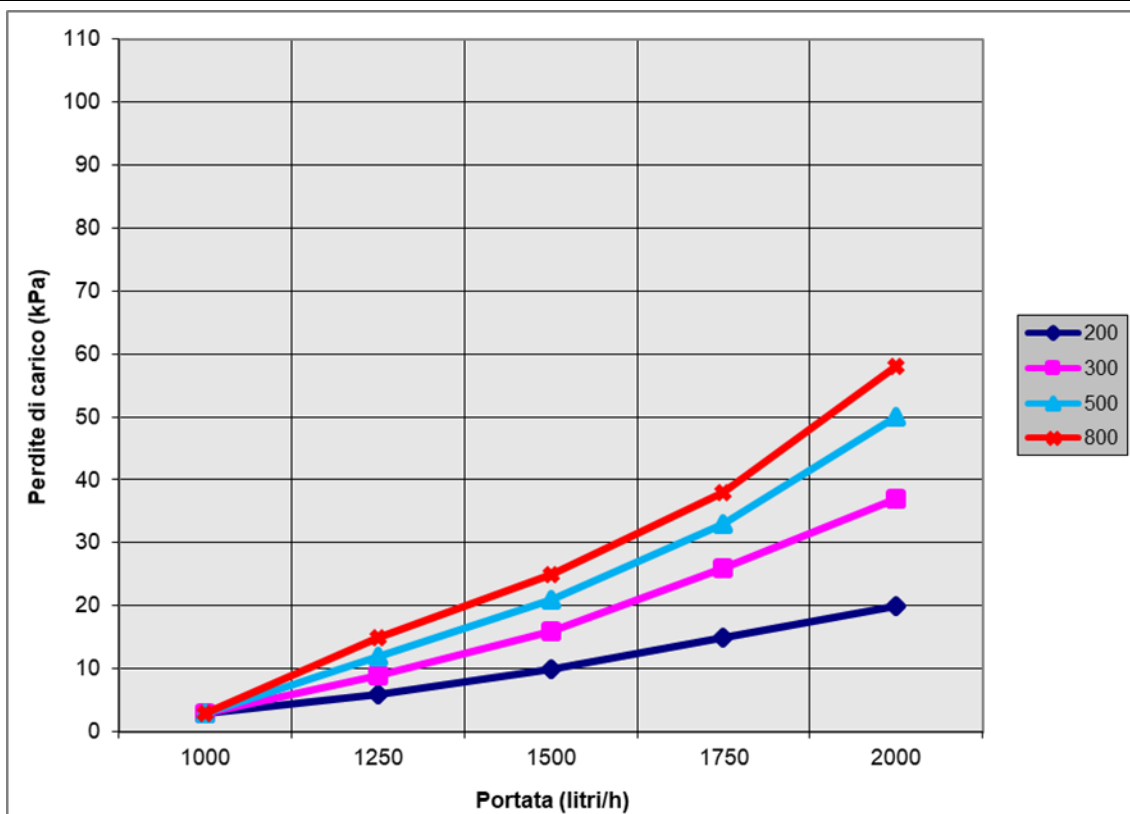

HOW TO ORDER

V → Vertical
O → Horizontal
R → Vert. LOW

6 → 6 bar
8 → 8 bar
0 → 10 bar

5 → Insulation 50 mm (Horizontal version)
8 → Insulations 80 mm
0 → Insulation 100 mm

A → Aluminium clad
NULL → PVC clad

Capacity

BTE H - V 8 C E O A / 1000

ACCESSORIES & SPARE PARTS

ITEM

PART NO.

THERMOMETER Ø65 mm | L=150 mm | (0÷120)°C *TERMOMETRO-D65_L*

THERMOMETER Ø100 mm | L=150 mm | (0÷120)°C *TERMOMETRO-D100*

PROBE SOCKET Ø½" | L=150 mm | Ø_{int}10 mm *POZZETTO_L*

THERMOSTAT Ø½" (0÷90)°C *TERMOSTATO*

ELECTRONIC ANODE KIT 200÷500 L *ANODE012X380_P*

ELECTRONIC ANODE KIT 800-1000 L *ANODE012X430_P*

ELECTRONIC ANODE KIT 1500÷2000 L *ANODE012X430X2_P*



THERMOMETER



PROBE SOCKET



THERMOSTAT



ELECTRONIC ANODE

1-3 PHASE IMMERSION ELECTRIC HEATER - STAINLESS STEEL 316 / INCOLOY TUBES
Threaded plug 1 1/2" with adapter for 2" diameter | Plastic box IP54 | V230/400

Power Watt	Phases distribution/ Voltage V	Capacity/L matching L	Length mm	2-THERMOSTAT Temp. regulation & overheating protection PART NO.
2000	Single-phase/230	200 ÷ 2000	310	RES020-L310-6-M-BT
3000	Single-phase/230	200 ÷ 2000	350	RES030-L350-6-M-BT
5000	Three-phase/400	200 ÷ 2000	375	RES050-L375-6-T-BT
6000	Three-phase/400	200 ÷ 2000	435	RES060-L435-6-T-BT
9000	Three-phase/400	500 ÷ 2000	610	RES090-L610-6-T-BT
10000	Three-phase/400	500 ÷ 2000	670	RES100-L670-6-T-BT
12000	Three-phase/400	800 ÷ 2000	730	RES120-L727-6-T-BT
15000	Three-phase/400	800 ÷ 2000	870	RES150-L870-6-T-BT



FLANGES REPLACEMENTS

ITEM	Capacity L	HEX Surface m ²	Diameter mm	PART NO.
ENAMELLED PLATE WITH ¾" HOLES	200 ÷ 500	0,76	300	PIASTRAN3001-076-C
ENAMELLED PLATE WITH ¾" HOLES		1,58	300	PIASTRAN3001-158-C
ENAMELLED PLATE WITH ¾" HOLES		2,27	300	PIASTRAN3001-227-C
ENAMELLED PLATE WITH ¾" HOLES		3,17	300	PIASTRAN3001-317-C
ENAMELLED PLATE WITH 1 ¼" HOLES	800 ÷ 2000	3,60	380	PIASTRAN3802-360-C
ENAMELLED PLATE WITH 1 ¼" HOLES		4,54	380	PIASTRAN3802-454-C
ENAMELLED PLATE WITH 1 ¼" HOLES		5,26	380	PIASTRAN3802-526_634-C
EPDM GASKET	200 ÷ 500	0,76 ÷ 3,17	220/300	GUGOMEPPDM300X220ST
EPDM GASKET	800 ÷ 2000	3,60 ÷ 5,26	300/380	GUGOMEPPDM380X300ST
SEAL KIT ¾"	200 ÷ 500	0,76 ÷ 3,17	—	KIT034
SEAL KIT 1 ¼"	800 ÷ 2000	3,60 ÷ 5,26	—	KIT114



PLATE



GASKET

SPIRAL FINNED COPPER COIL REMOVABLE HEAT EXCHANGERS

Heating surface area m ²	Connection Ø	Diameter D mm	Length L mm	PART NO.
0,76	¾"	140	440	SSPI076
1,58	¾"	170	510	SSPI158
2,27	¾"	170	670	SSPI227
3,17	¾"	190	665	SSPI317
3,60	1 ¼"	190	690	SSPI360
4,54	1 ¼"	190	780	SSPI454
5,26	1 ¼"	190	910	SSPI526

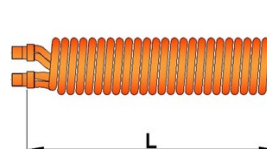

This page is left intentionally blank.

PROTECTIVE TREATMENTS FOR CARBON STEEL TANKS

CERAMFLON enamelling

The "CERAMFLON" anti-corrosion treatment is an innovative system for the protection of the metallic walls which has been introduced by the recent developments in the studies on resins, guaranteeing hygiene and many other qualities:

- it is inert and insensitive corrosion thanks to its considerable resistance to ageing;
- it is water-repellent and impermeable to steam and moisture;
- it has a practically zero absorption of humidity and the stability is maintained both at high and low temperatures, so they can withstand even very high thermal excursions;
- it has a high impact resistance and a very low friction coefficient, which avoids large and hazardous adherence phenomena which, in the majority of cases, can be attributed to limescale;
- it has a low dielectric constant which is maintained at variations in operating temperatures.

The application of the resins using triboelectric guns, carried out after careful cleaning of the support, is consolidated on the product after baking in an oven at 200°C.

CATHODIC PROTECTION

The corrosion of a metal structure occurs mainly in areas in which there is the passage of current (oxidation-reduction process) from the structure towards the outside (water or gas) causing a dissolution of the structure itself.

Cathodic protection by means of electronic impressed current system.

As an alternative to the galvanic system (coupling of materials with different potentials) there is a protection method which consists in applying an equal and opposite continuous current to the metallic structure to be protected, neutralising the voltages formed inside the tank.

Thanks to the modern techniques there is an innovative electronic system of cathodic protection with continuous impressed current.

The main advantages are:

- active protection by means of impressed currents from the outside;
- excellent flexibility of operation in order to adhere to the changeable internal coating conditions and the mass of water;
- reduction of maintenance costs due to the permanent protection of the system.



INSULATIONS

Insulating material	Removable	Thickness	Density	Thermal conductivity coefficient at 45°C	Operating temperature	Fire reaction class Euroclass EN13501-1
PLFH High Density Polyester fibre	✓	100 mm	25 kg/m ³	$\lambda = 0,034 \text{ W/mK}$	Amb. / +99°C	B-s2, d0
Injected Hard foam Polyurethane	✗	80 mm	40 ÷ 42 kg/m ³	$\lambda = 0,019 \text{ W/mK}$	-10°C / +99°C	F
Injected Hard foam Polyurethane	✗	50 mm	40 ÷ 42 kg/m ³	$\lambda = 0,019 \text{ W/mK}$	-10°C / +99°C	F

PLFH / PLF – Polyester fibre

- 100% recyclable
- Environmental friendly
- Lightweight
- Self-supporting
- Fire-retardant
- Rot-proof
- Resistant to mould, bacteria or rodents
- Hypoallergenic
- Water repellent



The raw materials consist of polyester fibres and heat-bonded co-polyester fibres, coming mainly from the recycling of plastic bottles obtained from urban waste collection.

It does not contain substances harmful to humans, may be handled and installed in complete safety, does not release powder, is hypoallergenic and cannot be attacked by microorganisms, mould and insects.

PLFH/PLF is a heat insulating product considered environmentally sustainable, even though it is not of natural origin: it is in fact recyclable and the quantity of embodied energy necessary to obtain it is extremely low.

The composition of the polyester fibre makes it an insulating material with an extremely low heat dispersion and its characteristics remain unaltered over time as it is not affected by humidity and its compact, flexible and resistant original structure is not modified.

Thanks to its characteristics, PLFH/PLF is an insulating material with the highest performance characteristics, which allows the requirements set by the severest technical standards to be satisfied, guaranteeing the maximum environmental compatibility for its entire life cycle.

Hard foam Polyurethane

Thermal and anti-condensation insulation made of hard closed cell polyurethane foam (PU), free from CFC and HCFC.

It is available in various thickness and can be injected directly to the shell of the tank to prevent it from condensation and provide the lower thermal dispersion. For some sizes it is pre-formed into half-shells to ease the insulation removal in case the tank has to pass through narrow doors.

CLADDINGS

PVC

External cladding made of coloured PVC with hinge closing, suitable for installations in locations protected against adverse weather conditions. The standard colours of each product are indicated in their construction characteristics, but different colours can be requested for each model as shown in the following table.

ITEM

PART NO.

PVC CLADDING YERLLOW RAL1023	COVER-RAL1023
PVC CLADDING OREANGE RAL2004	COVER-RAL2004
PVC CLADDING RED RAL3000	COVER-RAL3000
PVC CLADDING BLUE RAL5015	COVER-RAL5015
PVC CLADDING WHITE RAL9016	COVER-RAL9016
PVC CLADDING LIGHT GREY RAL7035	COVER-RAL7035
PVC CLADDING DARK GREY RAL7024	COVER-RAL7024
PVC CLADDING BLACK RAL9004	COVER-RAL9004



ALUMINIUM

External cladding made of embossed aluminium sheeting suitable also for outdoor installations. The insulations made with this type of cladding consist of panels joined together by means of rivets and extruded aluminium slats with an exclusive design, specifically designed to facilitate assembly even directly at the installation site.

The coverings and flange covers made of same material securely anchored to the insulation guarantee the same levels of quality in terms of duration and outside appearance and do not risk being damaged by the wind and adverse weather conditions.



www.pacetti.it



MADE IN ITALY

PACETTI S.r.l.

Via G. Marconi, 240/242

44122 - Ferrara - ITALY

Tel. +39 0532 774066

Fax +39 0532 773835

info@pacetti.it