

dal 1968



SCAMBIATORI - BOLLITORI - SERBATOI



BTIH-X - BTI-X

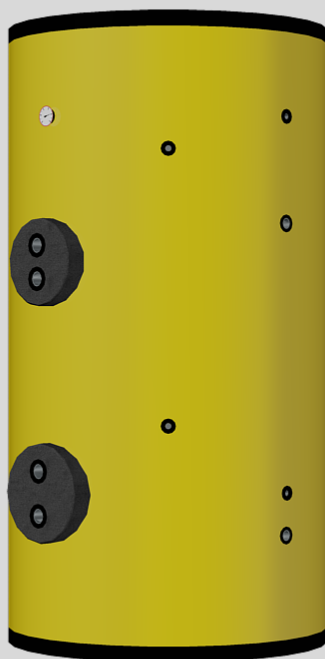

STAINLESS STEEL DHW CALORIFIER
EQUIPPED WITH TWO REMOVABLE TUBE BUNDLE HEAT
EXCHANGERS

STAINLESS STEEL DHW CALORIFIER EQUIPPED WITH TWO REMOVABLE TUBE BUNDLE HEAT EXCHANGERS

Calorifiers made of Stainless Steel AISI 316L pickled and passivated with two removable tube bundle heat exchangers for production and storage of DHW. Designed for connection to two different primary energy sources.

The lower coil is suitably sized to deliver the maximum heat transfer capacity to the entire volume of water contained in the tank; the upper coil, with a reduced heat exchange surface area, is instead designed to optimise the integration of another energy source in order to reach the desired temperature in the upper part of the tank and ensure the correct supply of domestic hot water even in systems using a combination of solar and traditional generators.

The calorifiers of the **BTIH-X | BTI-X** range stand out for the wide choice of capacities, from 1000 to 5000 L as standard and over upon request. They are available, in the larger sizes, in vertical-low and vertical extra-low versions to allow them to be installed in circumstances where the available height is not sufficient for the standard measurement. The two tube bundle heat exchangers, made of Stainless Steel AISI 316L as standard.

The possibility of selecting between various operating pressures - up to 10 bar - and the availability of different external claddings for indoor or outdoor installation, extends their use to all the possible applications.

CONSTRUCTION

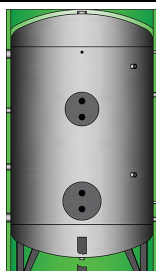

BTIH-X | BTI-X

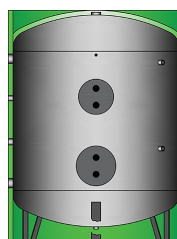

BTIH-RX | BTI-RX

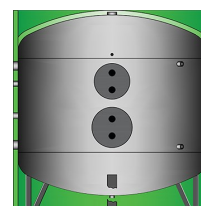

BTI-XX

	BTIH-X BTI-X	BTIH-RX BTI-RX	BTI-XX
TANK MATERIAL	Stainless steel AISI 316L	Stainless steel AISI 316L	Stainless steel AISI 316L
INTERNAL SURFACE TREATMENT	Pickling and passivation	Pickling and passivation	Pickling and passivation
EXTERNAL SURFACE TREATMENT	Pickling and passivation	Pickling and passivation	Pickling and passivation
CAPACITY	1000 ÷ 5000 L	1500 ÷ 5000 L	3000 ÷ 5000 L
VERSION	Vertical	Vertical-LOW	Vertical X-LOW
CONNECTIONS	Threaded	Threaded	Threaded
PRIMARY CHEST MATERIAL	Stainless steel AISI 316L	Stainless steel AISI 316L	Stainless steel AISI 316L
HEAT EXCHANGERS TUBES MATERIAL	Stainless steel AISI 316L	Stainless steel AISI 316L	Stainless steel AISI 316L
INSULATION 1000 L	Removable Hard Polyurethane cups 85 mm	—	—
INSULATION 1500-2000 L	PLFH (HD Polyester fibre) 120 mm	PLFH (HD Polyester fibre) 120 mm	—
INSULATION 2500 ÷ 5000 L	PLF (Polyester fibre) 50 mm	PLF (Polyester fibre) 50 mm	PLF (Polyester fibre) 50 mm
CLADDINGS	<ul style="list-style-type: none"> • PVC Yellow RAL1023 • Aluminium 	<ul style="list-style-type: none"> • PVC Yellow RAL1023 • Aluminium 	<ul style="list-style-type: none"> • PVC Yellow RAL1023 • Aluminium
ANODE TYPE	Electronic (optional)	Electronic (optional)	Electronic (optional)
ACCESSORIES (factory fitted)	Thermometer	Thermometer	Thermometer

Energy efficiency class - Regulation 812/2013 & 814/2013 | European Directive 2009/125/CE

				Capacity	1000	1500	2000
BTIH-X	Energy efficiency class				C	C	C
	Standing loss	S	W		118	168	187
	Storage volume	V	L		919	1513	1971
BTIH-RX	Energy efficiency class					C	C
	Standing loss	S	W			165	187
	Storage volume	V	L			1515	1978

STANDARD WORKING CONDITIONS

	Capacity	1000	1500	2000	2500	3000	4000	5000
Tank working pressure	bar	ATM ÷ 8	ATM ÷ 8	ATM ÷ 8	ATM ÷ 8	ATM ÷ 6	ATM ÷ 6	ATM ÷ 6
Tank working temperature	°C	AMB ÷ 99	AMB ÷ 99	AMB ÷ 99	AMB ÷ 99	AMB ÷ 99	AMB ÷ 99	AMB ÷ 99
Heat exchangers working pressure	bar	ATM ÷ 12	ATM ÷ 12	ATM ÷ 12	ATM ÷ 12	ATM ÷ 12	ATM ÷ 12	ATM ÷ 12
Heat exchangers working temperature	°C	AMB ÷ 99	AMB ÷ 99	AMB ÷ 99	AMB ÷ 99	AMB ÷ 99	AMB ÷ 99	AMB ÷ 99

REGULATORY COMPLIANCE

ErP - Reg. 812/2013 e Reg. 814/2013 | CE

European Pressure Equipment Directive (PED) 2014/68/UE | Sound Engineering Practice - excluded from CE marking - Art. 4.3

D.M. 174/04 | Suitable for contact with water for human consumption

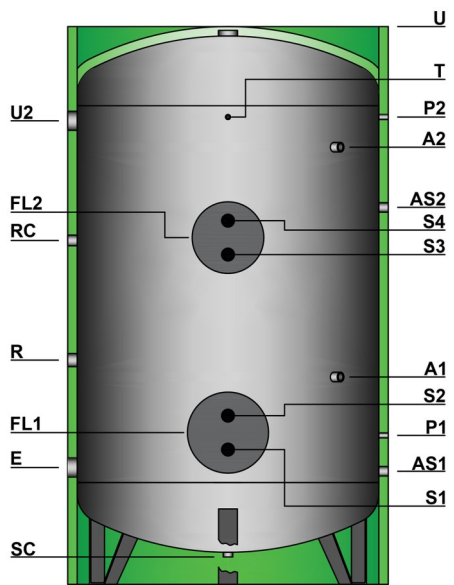

INSTALLATION ASSUMPTION

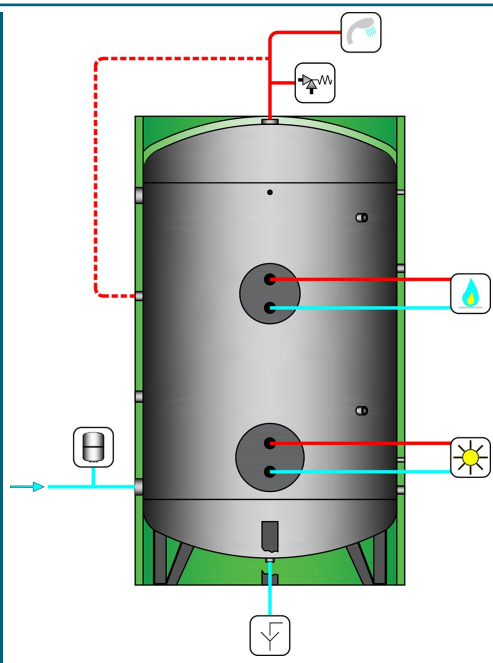

The proposed diagrams are for illustration purposes only.

GENERAL CHARACTERISTICS - VERTICAL STANDARD VERSION

	Capacity	1000	1500	2000	2500	3000	4000	5000
DIMENSIONS								
Diameter without insulation	mm	800	1000	1200	1200	1250	1400	1600
Diameter with insulation	mm	970	1240	1440	1300	1350	1500	1700
Overall height	mm	2185	2265	2184	2590	2790	2869	2960
Overturning height with without insulation	mm	2297 2201	2441 2270	2426 2197	2773 2595	2976 2795	3088 2878	3232 2977

CONNECTIONS								
E Cold water supply	mm Ø	420 2"	480 2"½	504 2"½	530 3"	525 3"	559 3"	620 3"
U DHW return	mm Ø	2185 2"	2265 2"½	2184 2"½	2590 3"	2790 3"	2869 3"	2960 3"
U2 DHW additional return	mm Ø	—	—	—	—	—	2399 3"	2460 3"
RC Recirculation	mm Ø	1405 1"½	1445 1"½	1319 1"½	1645 1"½	1730 1"½	1764 1"½	1825 1"½
R Immersion electric heater	mm Ø	1010 2"	950 2"	899 2"	1100 2"	1095 2"	1129 2"	1190 2"
P1 Sensor	mm Ø	610 ½"	650 ½"	649 ½"	700 ½"	695 ½"	729 ½"	790 ½"
P2 Sensor	mm Ø	1700 ½"	1680 ½"	1714 ½"	2190 ½"	2385 ½"	2419 ½"	2480 ½"
T Thermometer	mm Ø	1800 ½"	1840 ½"	1714 ½"	2190 ½"	2385 ½"	2419 ½"	2480 ½"
A1 Anode	mm Ø	810 ½"	860 ½"	834 ½"	1010 ½"	1005 ½"	1039 ½"	1100 ½"
A2 Anode	mm Ø	—	1680 ½"	1554 ½"	2030 ½"	2225 ½"	2259 ½"	2320 ½"
AS1 Spare	mm Ø	420 1"¼	450 1"¼	484 1"¼	510 1"¼	505 1"¼	539 1"¼	600 1"¼
AS2 Spare	mm Ø	1820 1"¼	1850 1"¼	1284 1"¼	1910 1"¼	1905 1"¼	1939 1"¼	2000 ½"
FL1 Lower heat exchanger manhole	mm	610	650	649	700	695	729	790
	Ø mm	300×380	300×380	300×380	300×380	300×380	350×430	350×430
FL2 Upper heat exchanger manhole	mm	1405	1445	1319	1645	1730	1764	1825
	Ø mm	220×300	300×380	300×380	300×380	300×380	300×380	300×380
S1 Lower heat exchanger return	mm Ø	535 2"	575 2"	574 2"	625 2"	620 2"	629 2"	690 2"
S2 Lower heat exchanger supply	mm Ø	685 2"	725 2"	724 2"	775 2"	770 2"	829 2"	890 2"
S3 Upper heat exchanger return	mm Ø	1345 1"	1370 2"	1244 2"	1570 2"	1655 2"	1689 2"	1750 2"
S4 Upper heat exchanger supply	mm Ø	1465 1"	1520 2"	1394 2"	1720 2"	1805 2"	1839 2"	1900 2"
SC Drain	mm Ø	95 1"¼	130 1"¼	109 1"¼	135 1"¼	125 1"¼	114 1"¼	145 1"¼

PERFORMANCES								
Lower heat exchanger heating surface area	m²	2,00	3,00	4,00	5,00	6,00	8,00	10,00
HEX Capacity (Prim. 80/70°C - Sec. 10/45°C)	kW	72	108	144	180	215	287	359
DHW Production 10/45°C	L/h	1764	2646	3529	4411	5293	7057	8821
Upper heat exchanger heating surface area	m²	1,00	1,50	2,00	2,50	3,00	4,00	5,00
HEX Capacity (Prim. 80/70°C - Sec. 10/45°C)	kW	36	54	72	90	108	144	180
DHW Production 10/45°C	L/h	882	1323	1764	2205	2646	3529	4411

EMPTY WEIGHTS								
Empty weight	kg	200	275	330	400	465	650	785

Note: All the measurements of the connections are considered "from the ground". The thread are female GAS type, unless otherwise specified. The tanks higher than 2200mm are packaged horizontally.



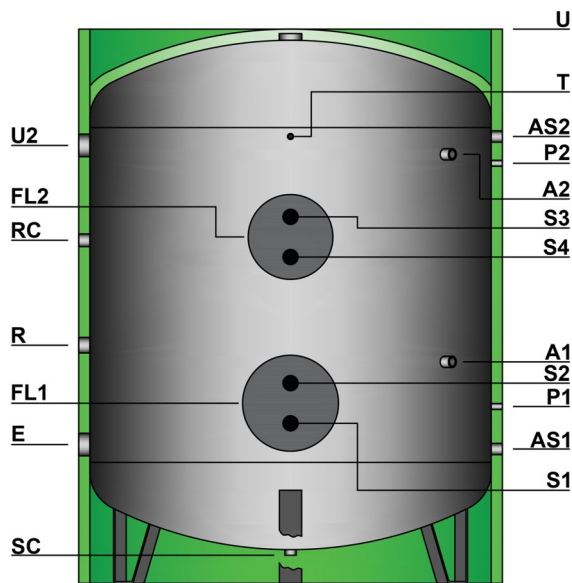

INSTALLATION ASSUMPTION

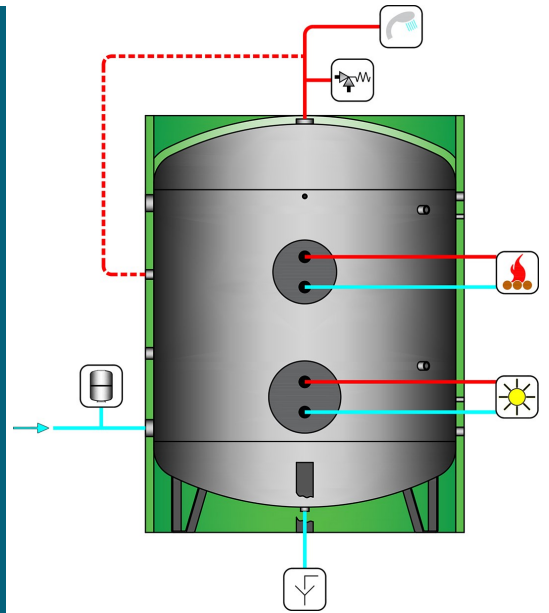

The proposed diagrams are for illustration purposes only.

GENERAL CHARACTERISTICS - VERTICAL - LOW VERSION

	Capacity	1500	2000	2500	3000	4000	5000
DIMENSIONS							
Diameter without insulation	mm	1100	1250	1400	1400	1600	1800
Diameter with insulation	mm	1340	1490	1500	1500	1700	1900
Overall height	mm	2035	2039	2119	2369	2460	2483
Overturning height with without insulation	mm	2264 2067	2319 2078	2410 2166	2632 2411	2771 2510	2874 2542

CONNECTIONS

E	Cold water supply	mm Ø	485 2"½	504 2"½	559 3"	559 3"	620 3"	622 3"
U	DHW return	mm Ø	2035 2"½	2039 2"½	2119 3"	2369 3"	2460 3"	2483 3"
U2	DHW additional return	mm Ø	—	—	1649 3"	1899 3"	1960 3"	1962 3"
RC	Recirculation	mm Ø	1235 1"½	1254 1"½	1309 1"½	1474 1"½	1535 1"½	1537 1"½
R	Immersion electric heater	mm Ø	865 2"	884 2"	939 2"	1004 2"	1065 2"	1067 2"
P1	Sensor	mm Ø	655 ½"	674 ½"	729 ½"	729 ½"	790 ½"	792
P2	Sensor	mm Ø	1595 ½"	1564 ½"	1669 ½"	1819 ½"	1880 ½"	1882
T	Thermometer	mm Ø	1595 ½"	1564 ½"	1669 ½"	1939 ½"	2000 ½"	2002
A1	Anode	mm Ø	870 ½"	889 ½"	944 ½"	929 ½"	990 ½"	992
A2	Anode	mm Ø	1535 ½"	1504 ½"	1609 ½"	1859 ½"	1920 ½"	1922
AS1	Spare	mm Ø	465 1"¼	484 1"¼	539 ½"	539 1"¼	600 1"¼	602 1"¼
AS2	Spare	mm Ø	1265 1"¼	1284 1"¼	1339 ½"	1939 1"¼	2000 1"¼	2002 1"¼
FL1	Lower heat exchanger manhole	mm Ø	655 300×380	674 300×380	729 300×380	729 300×380	790 350×430	792 350×430
FL2	Upper heat exchanger manhole	mm Ø	1235 300×380	1254 300×380	1309 300×380	1474 300×380	1535 300×380	1537 300×380
S1	Lower heat exchanger return	mm Ø	580 2"	599 2"	654 2"	654 2"	691 2"	622 2"
S2	Lower heat exchanger supply	mm Ø	730 2"	751 2"	804 2"	804 2"	891 2"	893 2"
S3	Upper heat exchanger return	mm Ø	1160 2"	1179 2"	1234 2"	1399 2"	1460 2"	1462 2"
S4	Upper heat exchanger supply	mm Ø	1310 2"	1329 2"	1384 2"	1549 2"	1610 2"	1612 2"
SC	Drain	mm Ø	123 1"¼	106 1"¼	114 1"¼	114 1"¼	145 1"¼	126 1"¼

PERFORMANCES

Lower heat exchanger heating surface area	m²	3,00	4,00	5,00	6,00	8,00	10,00
HEX Capacity (Prim. 80/70°C - Sec. 10/45°C)	kW	108	144	180	215	287	359
DHW Production 10/45°C	L/h	2646	3529	4411	5293	7057	8821
Upper heat exchanger heating surface area	m²	1,50	2,00	2,50	3,00	4,00	5,00
HEX Capacity (Prim. 80/70°C - Sec. 10/45°C)	kW	54	72	90	108	144	180
DHW Production 10/45°C	L/h	1323	1764	2205	2646	3529	4411

EMPTY WEIGHTS

Empty weight	kg	295	370	475	540	655	835
--------------	----	-----	-----	-----	-----	-----	-----

Note: All the measurements of the connections are considered "from the ground". The thread are female GAS type, unless otherwise specified. The tanks higher than 2200mm are packaged horizontally.

INSTALLATION ASSUMPTION

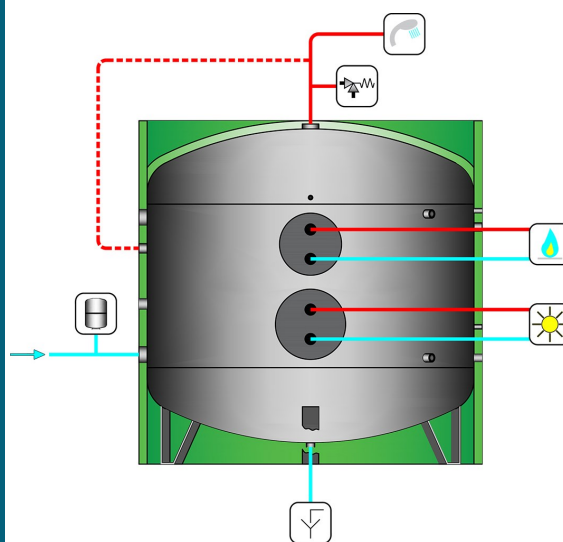
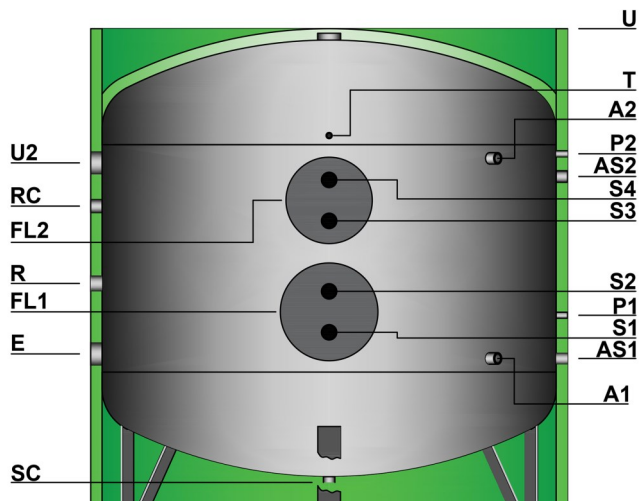

The proposed diagrams are for illustration purposes only.

GENERAL CHARACTERISTICS - VERTICAL EXTRA - LOW VERSION

	Capacity	3000	4000	5000
--	----------	------	------	------

DIMENSIONS

Diameter without insulation	mm	1500	1700	2000
Diameter with insulation	mm	1600	1800	2100
Overall height	mm	2130	2190	2100
Overturning height with without insulation	mm	2450 2158	2578 2249	2628 2179

CONNECTIONS

E Cold water supply	mm Ø	558 3"	590 3"	670 3"
U DHW return	mm Ø	2130 3"	2190 3"	2100 3"
U2 DHW additional return	mm Ø	1650 3"	1680 3"	1510 3"
RC Recirculation	mm Ø	1308 1"½	1370 1"½	1320 1"½
R Immersion electric heater	mm Ø	938 2"	1060 2"	1070 2"
P1 Sensor	mm Ø	728 ½"	790 ½"	850 ½"
P2 Sensor	mm Ø	1668 ½"	1700 ½"	1530 ½"
T Thermometer	mm Ø	1768 ½"	1700 ½"	1630 ½"
A1 Anode	mm Ø	943 ½"	570 ½"	650 ½"
A2 Anode	mm Ø	1668 ½"	1620 ½"	1530 ½"
AS1 Spare	mm Ø	538 1"¼	570 1"¼	650 1"¼
AS2 Spare	mm Ø	1337 1"¼	1370 1"¼	1450 1"¼
FL1 Lower heat exchanger manhole	mm Ø	728 300×380	790 350×430	850 350×430
FL2 Upper heat exchanger manhole	mm Ø	1513 300×380	1410 300×380	1340 300×380
S1 Lower heat exchanger return	mm Ø	653 2"	691 2"	751 2"
S2 Lower heat exchanger supply	mm Ø	803 2"	891 2"	951 2"
S3 Upper heat exchanger return	mm Ø	1438 2"	1335 2"	1265 2"
S4 Upper heat exchanger supply	mm Ø	1588 2"	1485 2"	1415 2"
SC Drain	mm Ø	103 1"¼	105 1"¼	105 1"¼

PERFORMANCES

Lower heat exchanger heating surface area	m²	6,00	8,00	10,00
HEX Capacity (Prim. 80/70°C - Sec. 10/45°C)	kW	215	287	359
DHW Production 10/45°C	Lh	5293	7057	8821
Upper heat exchanger heating surface area	m²	3,00	4,00	5,00
HEX Capacity (Prim. 80/70°C - Sec. 10/45°C)	kW	108	144	180
DHW Production 10/45°C	L/h	2646	3529	4411

EMPTY WEIGHTS

Empty weight	kg	540	700	825
--------------	----	-----	-----	-----

Note: All the measurements of the connections are considered "from the ground". The thread are female GAS type, unless otherwise specified. The tanks higher than 2200mm are packaged horizontally.



TUBE BUNDLE HEAT EXCHANGERS PRESSURE DROP

BTIH-X - BTI-X

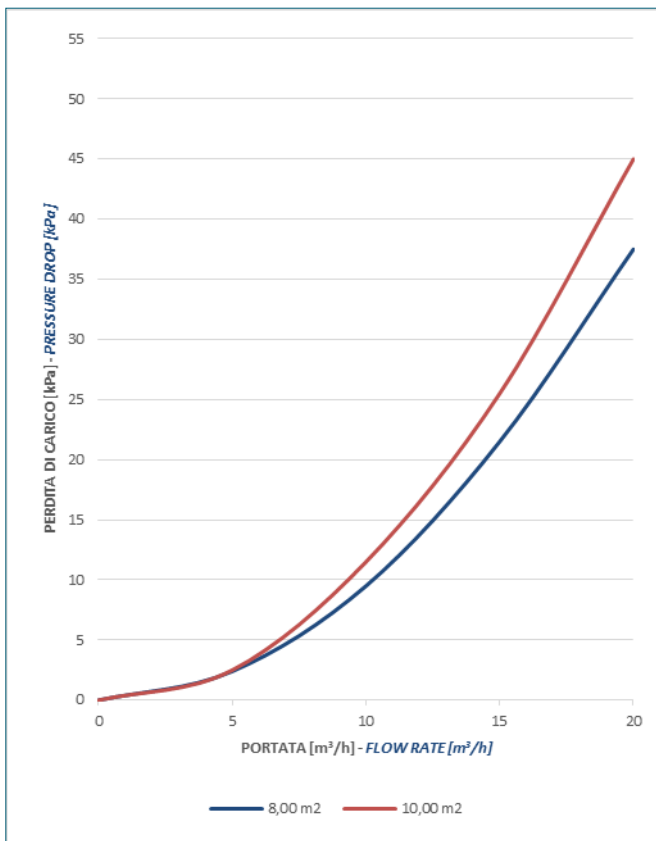
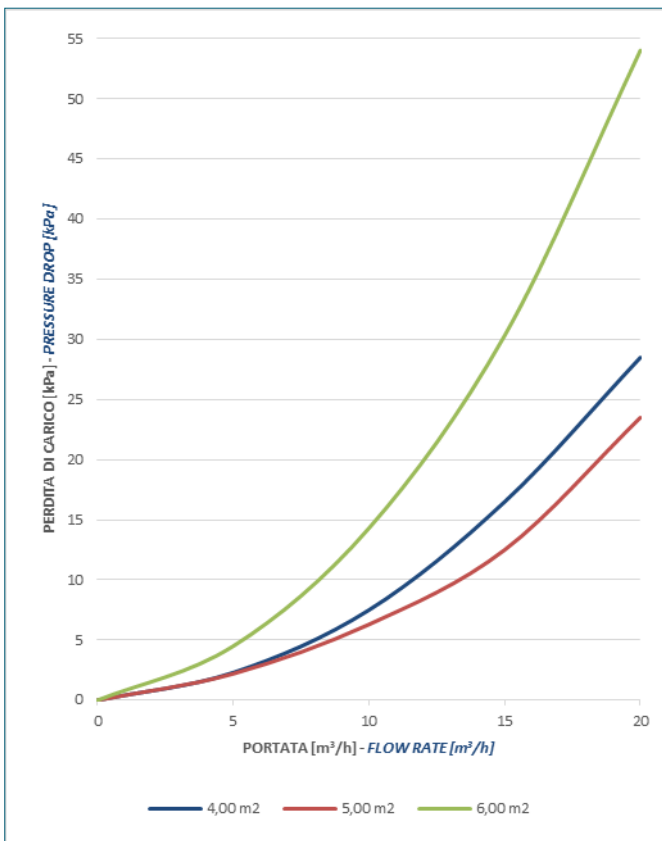
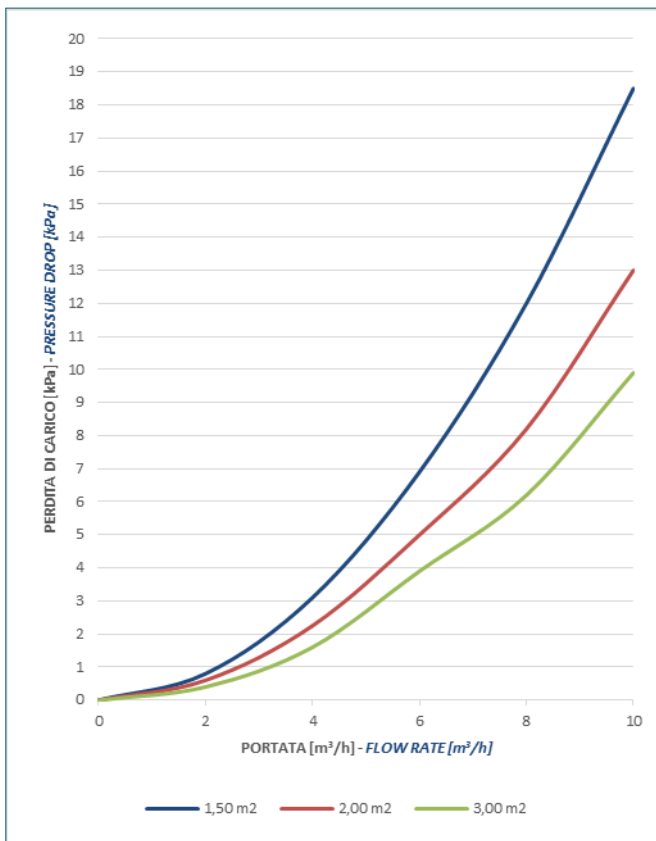
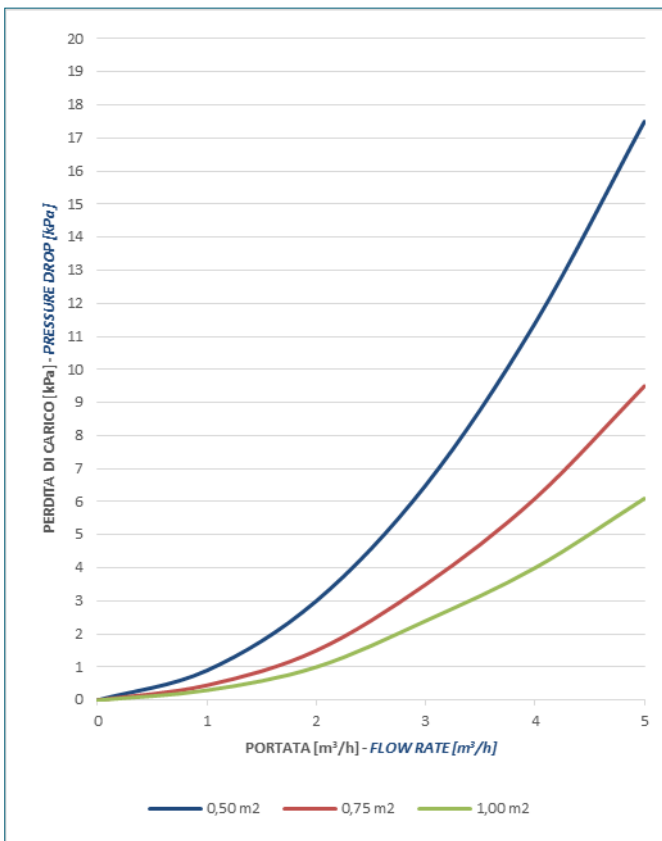

STAINLESS STEEL DHW CALORIFIER EQUIPPED WITH TWO REMOVABLE TUBE BUNDLE HEAT EXCHANGERS

LOWER TUBE BUNDLE HEAT EXCHANGER OUTPUT

Primary (80-70)°C | Secondary (10-45)°C

Storage Volume	Heating surface area	Capacity	Primary flow	SECONDARY SIDE		
				Continuous production	Production first 10'	Production first 60'
<i>L</i>	<i>m²</i>	<i>kW</i>	<i>L/h</i>	<i>L/h</i>	<i>L</i>	<i>L</i>
1000	2,00	72	6175	1764	1294	2764
1500	3,00	108	9263	2646	1941	4146
2000	4,00	144	12350	3529	2588	5529
2500	5,00	180	15438	4411	3235	6911
3000	6,00	215	18525	5293	3882	8293
4000	8,00	287	24700	7057	5176	11057
5000	10,00	359	30875	8821	6470	13821

Primary (70-60)°C | Secondary (10-45)°C

Storage Volume	Heating surface area	Capacity	Primary flow	SECONDARY SIDE		
				Continuous production	Production first 10'	Production first 60'
<i>L</i>	<i>m²</i>	<i>kW</i>	<i>L/h</i>	<i>L/h</i>	<i>L</i>	<i>L</i>
1000	2,00	52	4500	1286	1214	2286
1500	3,00	78	6750	1929	1821	3429
2000	4,00	105	9000	2571	2429	4571
2500	5,00	131	11250	3214	3036	5714
3000	6,00	157	13500	3857	3643	6857
4000	8,00	209	18000	5143	4857	9143
5000	10,00	262	22500	6429	6071	11429

Primary (60-50)°C | Secondary (10-45)°C

Storage Volume	Heating surface area	Capacity	Primary flow	SECONDARY SIDE		
				Continuous production	Production first 10'	Production first 60'
<i>L</i>	<i>m²</i>	<i>kW</i>	<i>L/h</i>	<i>L/h</i>	<i>L</i>	<i>L</i>
1000	2,00	35	3025	864	1144	1864
1500	3,00	53	4538	1296	1716	2796
2000	4,00	70	6050	1729	2288	3729
2500	5,00	88	7563	2161	2860	4661
3000	6,00	106	9075	2593	3432	5593
4000	8,00	141	12100	3457	4576	7457
5000	10,00	176	15125	4321	5720	9321

BTIH-X - BTI-X



UPPER TUBE BUNDLE HEAT EXCHANGER OUTPUT

Primary (80-70)°C | Secondary (10-45)°C

Storage Volume	Heating surface area	Capacity	Primary flow	SECONDARY SIDE
				Continuous Production
<i>L</i>	<i>m²</i>	<i>kW</i>	<i>L/h</i>	<i>L/h</i>
1000	1,00	36	3088	882
1500	1,50	54	4631	1323
2000	2,00	72	6175	1764
2500	2,50	90	7719	2205
3000	3,00	108	9263	2646
4000	4,00	144	12350	3529
5000	5,00	180	15438	4411

Primary (70-60)°C | Secondary (10-45)°C

Storage Volume	Heating surface area	Capacity	Primary flow	SECONDARY SIDE
				Continuous Production
<i>L</i>	<i>m²</i>	<i>kW</i>	<i>L/h</i>	<i>L/h</i>
1000	1,00	26	2250	643
1500	1,50	39	3375	964
2000	2,00	52	4500	1286
2500	2,50	65	5625	1607
3000	3,00	78	6750	1929
4000	4,00	105	9000	2571
5000	5,00	131	11250	3214

Primary (60-50)°C | Secondary (10-45)°C

Storage Volume	Heating surface area	Capacity	Primary flow	SECONDARY SIDE
				Continuous Production
<i>L</i>	<i>m²</i>	<i>kW</i>	<i>L/h</i>	<i>L/h</i>
1000	1,00	18	1513	432
1500	1,50	26	2269	648
2000	2,00	35	3025	864
2500	2,50	44	3781	1080
3000	3,00	53	4538	1296
4000	4,00	70	6050	1729
5000	5,00	88	7563	2161

STAINLESS STEEL DHW CALORIFIER EQUIPPED WITH TWO REMOVABLE TUBE BUNDLE HEAT EXCHANGERS

HOW TO ORDER

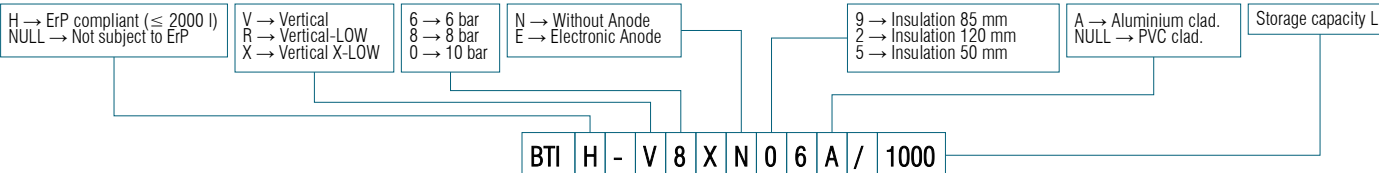

ACCESSORIES & SPARE PARTS

ITEM	PART NO.			
THERMOMETER Ø65 mm L=150 mm (0÷120)°C	TERMOMETRO-D65_L			
THERMOMETER Ø100 mm L=150 mm (0÷120)°C	TERMOMETRO-D100			
PROBE SOCKET Ø½" L=150 mm Ø _{int} 10 mm	POZZETTO_L			
THERMOSTAT Ø½" (0÷90)°C	TERMOSTATO			
TITANIUM ANODE for SS 316L tanks 1000 L	ANODE_ARTHX1-150/400			
TITANIUM ANODE for SS 316L tanks 1500-5000 L	ANODE_ARTHX2-150/400			ELECTRONIC ANODE

1-PHASE & 3-PHASE IMMERSION ELECTRIC HEATER - STAINLESS STEEL 316L TUBES Threaded plug 1.1/2" with brass adapter 1.1/2" to 2" | Aluminium box IP54 | V220/1-V240/1 or V400/3

Capacity	Capacity/L matching	Length	Volt	Plug type	2-THERMOSTAT Temperature regulation & overheating protection	PART NO.	
Watt	L	mm	mm	mm			
2000	1000 ÷ 5000	310	220/1	SHUKO		RES020-L310-6-M-BT	
3000	1000 ÷ 5000	350	240/1			RES030-L350-6-M-BT	
5000	1000 ÷ 5000	375	400/3	Not supplied		RES050-L375-6-T-BT	
6000	1000 ÷ 5000	435				RES060-L435-6-T-BT	
9000	1000 ÷ 5000	610				RES090-L610-6-T-BT	
10000	1000 ÷ 5000	670				RES100-L670-6-T-BT	
12000	1000 ÷ 5000	730				RES120-L727-6-T-BT	
15000	1500 ÷ 5000	870				RES150-L870-6-T-BT	

PRIMARY CHESTS AND SEALING GASKETS

Diameter Internal × External mm	Capacity L	Primary chest made of stainless steel Part no.	EPDM gasket without cross bar Part no.	EPDM gasket with cross bar Part no.
220×300	1000	TESTA300X220X5-X	GUGOMEPDM300X220ST	GUGOMEPDM300X220CT
300×380	1000 ÷ 5000	TESTA380X300X5-X	GUGOMEPDM380X300ST	GUGOMEPDM380X300CT
350×430	4000-5000	TESTA430X350X5-X	GUGOMEPDM430X350ST	GUGOMEPDM430X350CT

TUBE BUNDLE HEAT EXCHANGERS

Heating surface area m ²	Dimensions		Stainless Steel AISI 316L tubes & Stainless steel plate Part no.
	D	L	
mm	mm	mm	
1,00	300	473	SFX6010D300-X
1,50	380	594	SFX6015D380-X
2,00	380	594	SFX6020D380-X
2,50	380	594	SFX6025D380-X
3,00	380	718	SFX6030D380-X
4,00	380	850	SFX6040D380-X
5,00	380	1050	SFX6050D380-X
6,00	380	1250	SFX6060D380-X
8,00	430	1250	SFX6080D430-X
10,00	430	1510	SFX6100D430-X



BTI-H-X - BTI-X



PROTECTIVE TREATMENTS FOR STAINLESS STEEL TANKS

Pickling and passivation

DHW storage tanks made of Stainless Steel 316L are treated with full immersion pickling procedures and subsequent passivation to ensure the highest hygiene standards

CATHODIC PROTECTION

The corrosion of a metal structure occurs mainly in areas in which there is the passage of current (oxidation-reduction process) from the structure towards the outside (water or gas) causing a dissolution of the structure itself.

Cathodic protection by means of electronic impressed current system.

As an alternative to the galvanic system (coupling of materials with different potentials) there is a protection method which consists in applying an equal and opposite continuous current to the metallic structure to be protected, neutralising the voltages formed inside the tank.

Thanks to the modern techniques there is an innovative electronic system of cathodic protection with continuous impressed current.

The main advantages are:

- active protection by means of impressed currents from the outside;
- excellent flexibility of operation in order to adhere to the changeable internal coating conditions and the mass of water;

reduction of maintenance costs due to the permanent protection of the system



INSULATIONS

Insulating material	Removable	Thickness	Density	Thermal conductivity coefficient at 45°C	Operating temperature	Fire reaction class Euroclass EN13501-1
PLF Polyester fibre	✓	50 mm	20 kg/m ³	$\lambda = 0,037 \text{ W/mK}$	Amb. / +99°C	B-s2, d0
PLFH High Density Polyester fibre	✓	120 mm	25 kg/m ³	$\lambda = 0,034 \text{ W/mK}$	Amb. / +99°C	B-s2, d0
Removable Hard Polyurethane cups	✓	85 mm	40 ÷ 42 kg/m ³	$\lambda = 0,019 \text{ W/mK}$	Amb. / +99°C	F

PLFH / PLF – Polyester fibre

- 100% recyclable
- Environmental friendly
- Lightweight
- Self-supporting
- Fire-retardant
- Rot-proof
- Resistant to mould, bacteria or rodents
- Hypoallergenic
- Water repellent



The raw materials consist of polyester fibres and heat-bonded co-polyester fibres, coming mainly from the recycling of plastic bottles obtained from urban waste collection.

It does not contain substances harmful to humans, may be handled and installed in complete safety, does not release powder, is hypoallergenic and cannot be attacked by microorganisms, mould and insects.

PLFH/PLF is a heat insulating product considered environmentally sustainable, even though it is not of natural origin: it is in fact recyclable and the quantity of embodied energy necessary to obtain it is extremely low.

The composition of the polyester fibre makes it an insulating material with an extremely low heat dispersion and its characteristics remain unaltered over time as it is not affected by humidity and its compact, flexible and resistant original structure is not modified.

Thanks to its characteristics, PLFH/PLF is an insulating material with the highest performance characteristics, which allows the requirements set by the severest technical standards to be satisfied, guaranteeing the maximum environmental compatibility for its entire life cycle.

Hard foam Polyurethane

Thermal and anti-condensation insulation made of hard closed cell polyurethane foam (PU), free from CFC and HCFC.

It is available in various thickness and can be injected directly to the shell of the tank to prevent it from condensation and provide the lower thermal dispersion. For some sizes it is pre-formed into half-shells to ease the insulation removal in case the tank has to pass through narrow doors.

CLADDINGS

PVC

External cladding made of coloured PVC with hinge closing, suitable for installations in locations protected against adverse weather conditions. The standard colours of each product are indicated in their construction characteristics, but different colours can be requested for each model as shown in the following table.

ITEM

PART NO.

PVC CLADDING YERLLOW RAL1023	COVER-RAL1023
PVC CLADDING OREANGE RAL2004	COVER-RAL2004
PVC CLADDING RED RAL3000	COVER-RAL3000
PVC CLADDING BLUE RAL5015	COVER-RAL5015
PVC CLADDING WHITE RAL9016	COVER-RAL9016
PVC CLADDING LIGHT GREY RAL7035	COVER-RAL7035
PVC CLADDING DARK GREY RAL7024	COVER-RAL7024
PVC CLADDING BLACK RAL9004	COVER-RAL9004



ALUMINIUM

External cladding made of embossed aluminium sheeting suitable also for outdoor installations. The insulations made with this type of cladding consist of panels joined together by means of rivets and extruded aluminium slats with an exclusive design, specifically designed to facilitate assembly even directly at the installation site.

The coverings and flange covers made of same material securely anchored to the insulation guarantee the same levels of quality in terms of duration and outside appearance and do not risk being damaged by the wind and adverse weather conditions.



www.pacetti.it



MADE IN ITALY

PACETTI S.r.l.

Via G. Marconi, 240/242

44122 - Ferrara - ITALY

Tel. +39 0532 774066

Fax +39 0532 773835

info@pacetti.it