

dal 1968



SCAMBIATORI - BOLLITORI - SERBATOI



# PRSH-C

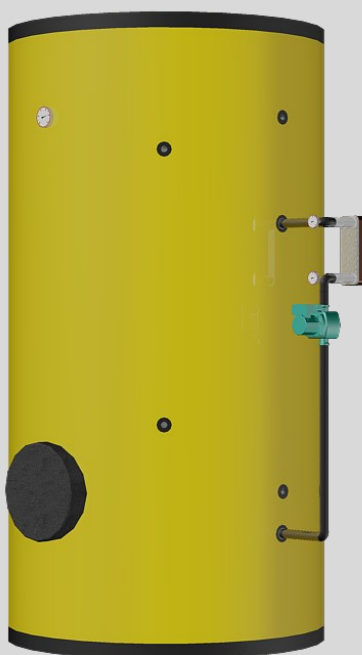

SEMI-INSTANTANEOUS WATER HEATER  
ENAMELLED STEEL DHW STORAGE TANK  
WITH EXTERNAL BRAZED PLATE HEAT EXCHANGER KIT

This integrated system is designed for the storage and rapid production of Domestic Hot Water and can suit any installation type. Combining a DHW storage tank (**TAH-C**) with an external brazed plate heat exchanger kit (**BV26**) and a Stainless Steel circulator allows high volumes and simultaneous DHW demand to be met while keeping the tank volume reduced. This is an ideal solution for applications with significant peak draw-off rates, such as sports centres, hotels, restaurants and apartment buildings, where storage recovery time is critical to meeting high peak demand. The **PRSH-S** is supplied fully assembled to speed up installation. The provision of an electronic anode and inspection manhole for routine cleaning as part of the DHW storage tank results in a top-level quality product. The DHW storage tank is equipped with an electronic anode and an inspection manhole to facilitate internal cleaning during routine maintenance. The fully insulated galvanised piping kit includes two thermometers at the heat exchanger's inlet and outlet, enabling to instantly monitor operating conditions and assess heat transfer efficiency. This enables routine maintenance to be scheduled, thereby preventing potential drops in performance.. A thermostat is also provided and installed on the storage tank to control the start-up and shutdown of the connected energy source. Find out more on TAH-C and BV 26 brochures.

CONSTRUCTION

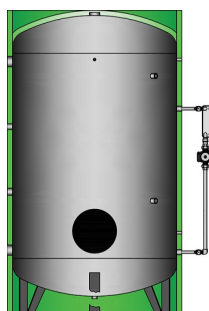

PRSH-C

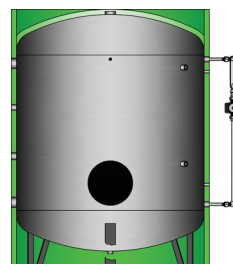

PRSH-RC

DHW STORAGE TANK		PRSH-C	PRSH-RC
TANK MATERIAL		Carbon steel	Carbon steel
INT. SURFACE STEEL TREATMENT		CERAMFLON enamel	CERAMFLON enamel
EXT. SURFACE STEEL TREATMENT		Anti-rust primer	Anti-rust primer
CAPACITY		200 ÷ 2000 L	200 ÷ 2000 L
VERSION		Vertical	Vertical LOW-height
CONNECTION TYPE		Threaded	Threaded
INSULATION   200 ÷ 500 L		Hard foam Polyurethane injected 80 mm	—
INSULATION   800 ÷ 2000 L		PLFH (HD Polyester fibre) 100 mm	PLFH (HD Polyester fibre) 100 mm
OUTER CLADDING		<ul style="list-style-type: none"> <li>• PVC Yellow RAL1023</li> <li>• Aluminium</li> </ul>	<ul style="list-style-type: none"> <li>• PVC Yellow RAL1023</li> <li>• Aluminium</li> </ul>
ANODE TYPE		Electronic	Electronic
ACCESSORIES (factory fitted)		Thermometer	Thermometer
EXTERNAL COPPER BRAZED PLATE HEAT EXCHANGER KIT			
COPPER BRAZED PHE MODEL		<b>BV 26</b>	<b>BV 26</b>
PALTES MATERIAL		Stainless Steel AISI 316L	Stainless Steel AISI 316L
PIPEWORK MATERIAL		Galvanized steel	Galvanized steel
ACCESSORIES (factory fitted)		<ul style="list-style-type: none"> <li>• PHE temp. gauges (in/out)</li> <li>• Thermostat</li> <li>• DHW circulator pump</li> </ul>	<ul style="list-style-type: none"> <li>• PHE temp. gauges (in/out)</li> <li>• Thermostat</li> <li>• DHW circulator pump</li> </ul>

Energy efficiency class - Regulation EU 812/2013 & 814/2013 (European Directive 2009/125/CE)

		Capacity	200	300	500	800	1000	1500	2000
PRSH-C	Energy efficiency class		<b>B</b>	<b>B</b>	<b>B</b>	<b>C</b>	<b>C</b>	<b>C</b>	<b>C</b>
	Standing loss	S W	55	64	81	133	144	168	190
	Storage volume	V L	193	296	505	796	920	1491	1998
PRSH-RC	Energy efficiency class							<b>C</b>	<b>C</b>
	Standing loss	S W						167	185
	Storage volume	V L						1529	1973

STANDARD WORKING CONDITIONS

		Capacity - L	200	300	500	800	1000	1500	2000
Working pressure	Enamelled tank and galvanized steel pipework	bar	ATM ÷ 8	ATM ÷ 8	ATM ÷ 8	ATM ÷ 8	ATM ÷ 8	ATM ÷ 8	ATM ÷ 8
	Brazed Plate heat exchanger [primary side]	bar	ATM ÷ 30	ATM ÷ 30	ATM ÷ 30	ATM ÷ 30	ATM ÷ 30	ATM ÷ 30	ATM ÷ 30
Working temperature	Enamelled tank and galvanized steel pipework	°C	AMB ÷ 85	AMB ÷ 85	AMB ÷ 85	AMB ÷ 85	AMB ÷ 85	AMB ÷ 85	AMB ÷ 85
	Brazed Plate heat exchanger [primary side]	°C	-160 ÷ 200	-160 ÷ 200	-160 ÷ 200	-160 ÷ 200	-160 ÷ 200	-160 ÷ 200	-160 ÷ 200

REGULATORY COMPLIANCE

ErP - Reg. 812/2013 e Reg. 814/2013 | CE  
 European Pressure Equipment Directive (PED) 2014/68/UE | Sound Engineering Practice - excluded from CE marking - Art. 4.3  
 D.M. 174/04 | Suitable for contact with water for human consumption

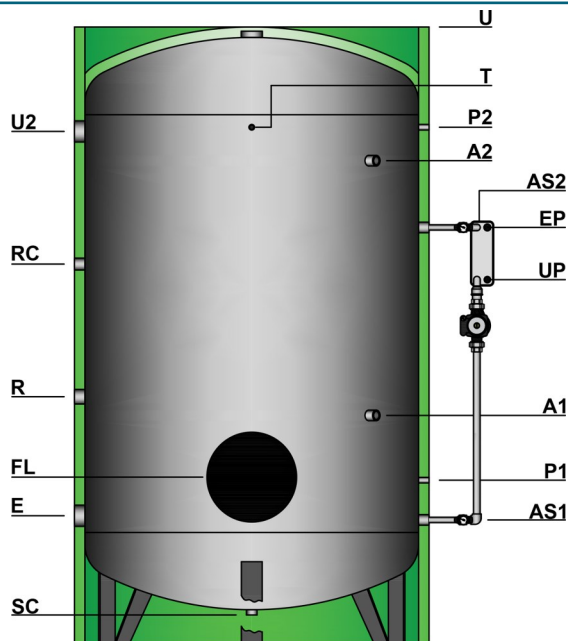

INSTALLATION ASSUMPTIONS

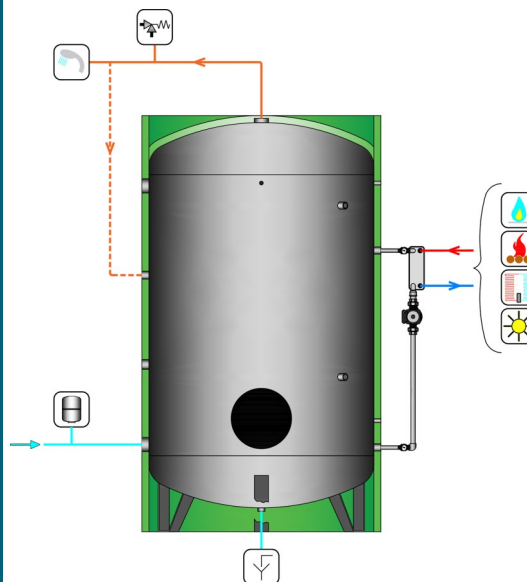

GENERAL CHARACTERISTICS - VERTICAL STANDARD VERSION

	Capacity	200	300	500	800	1000	1500	2000	
<b>DIMENSIONS</b>									
Diameter without insulation	mm	450	550	650	800	800	950	1100	
Diameter with insulation	mm	610	710	810	1000	1000	1150	1300	
Overall height	mm	1515	1554	1844	1950	2200	2510	2535	
PHE kit side space	mm	960	1060	1160	1350	1350	1500	1650	
Overturning height with   without insulation	mm	1577   —	1638   —	1936   —	2114   1933	2316   2166	2654   2502	2712   2541	
<b>CONNECTIONS</b>									
		<b>H from ground   Ø</b>							
E Cold water supply	mm   Ø	355   1"½	369   1"½	384   1"½	420   2"	420   2"	465   2"½	485   2"½	
U DHW return	mm   Ø	1515   1"½	1554   1"½	1844   1"½	1950   2"	2200   2"	2510   2"½	2535   2"½	
U2 Additional DHW return	mm   Ø	—	—	—	—	—	—	—	
RC Recirculation	mm   Ø	1005   1"½	1019   1"½	1259   1"½	1370   1"½	1405   1"½	1580   1"½	1600   1"½	
R Immersion electric heater	mm   Ø	775   2"	789   2"	804   2"	1010   2"	1010   2"	1035   2"	1055   2"	
P1 Sensor	mm   Ø	475   ½"	489   ½"	504   ½"	610   ½"	610   ½"	635   ½"	655   ½"	
P2 Sensor	mm   Ø	1255   ½"	1269   ½"	1534   ½"	1550   ½"	1700   ½"	2125   ½"	2095   ½"	
T Thermometer	mm   Ø	1255   ½"	1269   ½"	1534   ½"	1550   ½"	1800   ½"	2125   ½"	2095   ½"	
A1 Anode	mm   Ø	855   ½"	869   ½"	884   ½"	920   ½"	920   ½"	945   ½"	965   ½"	
A2 Anode	mm   Ø	—	—	—	—	—	1965   ½"	1935   ½"	
AS1 PHE fitting	mm   Ø	355   1"¼	369   1"¼	384   1"¼	420   1"¼	420   1"¼	445   1"¼	465   1"¼	
AS2 PHE fitting	mm   Ø	1155   1"¼	1169   1"¼	1184   1"¼	1220   1"¼	1820   1"¼	1845   1"¼	1865   1"¼	
EP Primary inlet (PHE)	mm   Ø	1155   1"M	1169   1"M	1184   1"M	1220   1"M	1820   1"M	1845   1"M	1865   1"M	
UP Primary outlet (PHE)	mm   Ø	905   1"M	919   1"M	934   1"M	970   1"M	1570   1"M	1595   1"M	1615   1"M	
SC Drain	mm   Ø	145   1"¼	134   1"¼	124   1"¼	120   1"¼	120   1"¼	160   1"¼	145   1"¼	
FL Inspection manhole	mm   Ø	475   220x300	489   220x300	504   220x300	610   300x380	610   300x380	635   300x380	655   300x380	
<b>EMPTY WEIGHTS</b>									
Empty weight	kg	65	75	105	140	155	215	275	

Note: All the measurements of the connections are considered "from the ground". The thread are female GAS type, unless otherwise specified. The tanks higher than 2200mm are packaged horizontally.

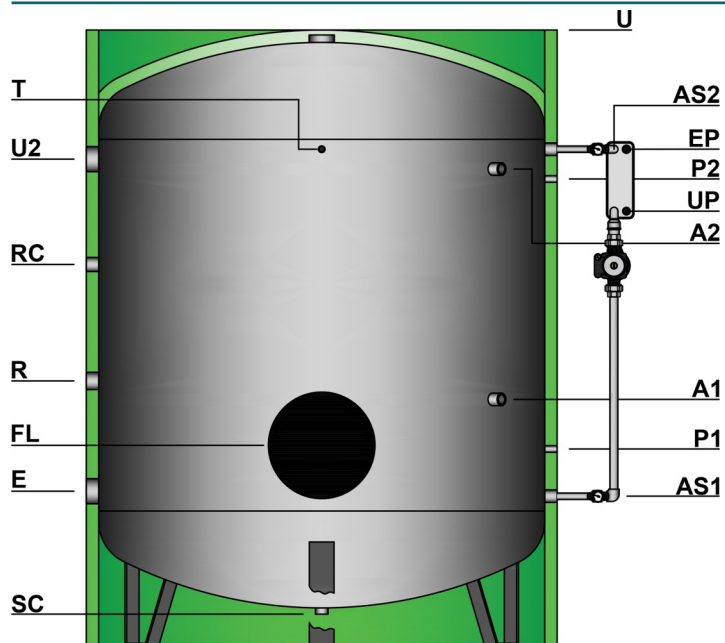

INSTALLATION ASSUMPTIONS

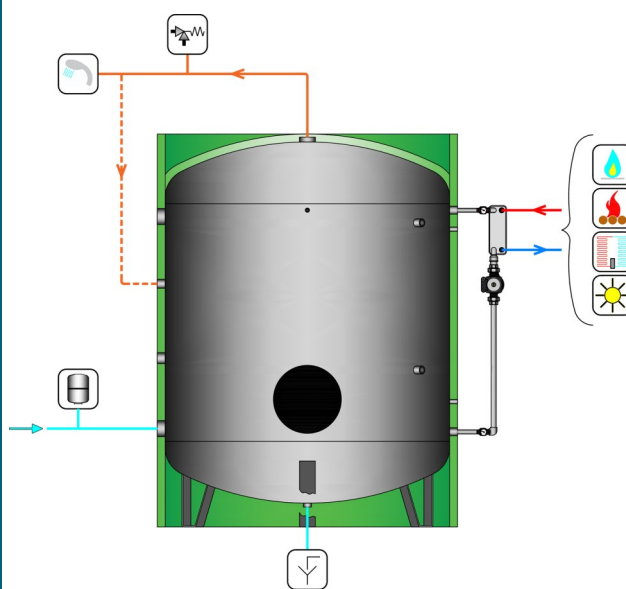

The proposed diagrams are for illustration purposes only.

GENERAL CHARACTERISTICS - VERTICAL LOW HEIGHT VERSION

	Capacity	1500	2000
<b>DIMENSIONS</b>			
Diameter without insulation	mm	1100	1250
Diameter with insulation	mm	1300	1450
Overall height	mm	2015	2039
PHE kit side space	mm	1650	1800
Overturning height with   without insulation	mm	2237   2019	2310   2059
<b>CONNECTIONS</b>			
	<b>H from ground   Ø</b>		
E Cold water supply	mm   Ø	485   2"½	504   2"½
U DHW return	mm   Ø	2015   2"½	2039   2"½
U2 Additional DHW return	mm   Ø	—	—
RC Recirculation	mm   Ø	1235   1"½	1254   1"½
R Immersion electric heater	mm   Ø	865   2"	884   2"
P1 Sensor	mm   Ø	655   ½"	674   ½"
P2 Sensor	mm   Ø	1595   ½"	1564   ½"
T Thermometer	mm   Ø	1595   ½"	1564   ½"
A1 Anode	mm   Ø	870   ½"	864   ½"
A2 Anode	mm   Ø	1535   ½"	1504   ½"
AS1 PHE fitting	mm   Ø	465   1"¼	484   1"¼
AS2 PHE fitting	mm   Ø	1265   1"¼	1284   1"¼
EP Primary inlet (PHE)	mm   Ø	1265   1"M	1284   1"M
UP Primary outlet (PHE)	mm   Ø	1015   1"M	1034   1"M
FL Inspection manhole	mm   Ø	655   300×380	674   300×380
SC Drain	mm   Ø	145   1"¼	129   1"¼
<b>EMPTY WEIGHTS</b>			
Empty weight	kg	260	310

Note: All the measurements of the connections are considered "from the ground". The thread are female GAS type, unless otherwise specified. The tanks higher than 2200mm are packaged horizontally.

PERFORMANCE AND MATCHING TABLES FOR BV26 BRAZED PLATE HEAT EXCHANGER

Primary (80-60)°C | Secondary (12-48)°C | Primary side pressure drop: 40 kPa | Secondary side pressure drop: 20 kPa

Capacity L	BV26 Plates No.	Power kW	Primary flow L/h	Continuous production L/h	Production first 10' L	Production first 60' L	Recovery time minutes	NUMBER OF BATHROOMS / SHOWERS			
								Apartments	Hotels	Seasonal hotels	Sport facilities
200	20	70	3001	1667	478	1867	7	23	16	12	9
	30	105	4502	2501	617	2701	5	34	23	17	14
	40	140	5999	3333	755	3533	4	44	29	22	18
	50	170	7250	4028	871	4228	3	53	35	26	21
300	20	70	3001	1667	578	1967	11	26	17	13	10
	30	105	4502	2501	717	2801	7	37	25	18	15
	40	140	5999	3333	855	3633	5	48	32	24	19
	50	170	7250	4028	971	4328	4	57	38	28	23
500	20	70	3001	1667	778	2167	18	30	20	15	12
	30	105	4502	2501	917	3001	12	42	28	21	17
	40	140	5999	3333	1055	3833	9	53	35	27	21
	50	170	7250	4028	1171	4528	7	63	42	31	25
800	20	70	3001	1667	1078	2467	29	36	24	18	15
	30	105	4502	2501	1217	3301	19	49	32	24	19
	40	140	5999	3333	1355	4133	14	61	41	30	24
	50	170	7250	4028	1471	4828	12	71	47	35	28
1000	20	70	3001	1667	1278	2667	36	42	28	21	17
	30	105	4502	2501	1417	3501	24	55	36	27	22
	40	140	5999	3333	1555	4333	18	68	45	34	27
	50	170	7250	4028	1671	5028	15	79	52	39	31
1500	20	70	3001	1667	1778	3167	54	53	35	26	21
	30	105	4502	2501	1917	4001	36	67	44	33	27
	40	140	5999	3333	2055	4833	27	81	54	40	32
	50	170	7250	4028	2171	5528	22	92	61	46	37
2000	20	70	3001	1667	2278	3667	72	65	44	33	26
	30	105	4502	2501	2417	4501	48	80	54	40	32
	40	140	5999	3333	2555	5333	36	95	63	48	38
	50	170	7250	4028	2671	6028	30	108	72	54	43

PRSH-C



PERFORMANCE AND MATCHING TABLES FOR BV26 BRAZED PLATE HEAT EXCHANGER

Primary (65-50)°C | Secondary (12-48)°C | Primary side pressure drop: 40 kPa | Secondary side pressure drop: 20 kPa

Capacity L	BV26 Plates No.	Power kW	Primary flow L/h	Continuous production L/h	Production first 10 L	Production first 60 L	Recovery time minutes	NUMBER OF BATHROOMS / SHOWERS			
								Apartments	Hotels	Seasonal hotels	Sport facilities
200	20	36	2113	860	343	1060	14	13	9	7	5
	30	60	3522	1435	439	1633	8	20	14	10	8
	40	85	4989	2033	538	2231	6	28	19	14	11
	50	115	6750	2750	658	2947	4	37	25	18	15
300	20	36	2113	860	443	1160	21	15	10	8	6
	30	60	3522	1435	539	1733	13	23	15	11	9
	40	85	4989	2033	638	2331	9	31	20	15	12
	50	115	6750	2750	758	3047	7	40	27	20	16
500	20	36	2113	860	643	1360	35	19	13	9	8
	30	60	3522	1435	739	1933	21	27	18	13	11
	40	85	4989	2033	838	2531	15	35	23	18	14
	50	115	6750	2750	958	3247	11	45	30	23	18
800	20	36	2113	860	943	1660	56	24	16	12	10
	30	60	3522	1435	1039	2233	33	33	22	16	13
	40	85	4989	2033	1138	2831	24	42	28	21	17
	50	115	6750	2750	1258	3547	17	52	35	26	21
1000	20	36	2113	860	1143	1860	70	29	19	15	12
	30	60	3522	1435	1239	2433	42	38	25	19	15
	40	85	4989	2033	1338	3031	30	47	32	24	19
	50	115	6750	2750	1458	3747	22	59	39	29	23
1500	20	36	2113	860	1643	2360	105	39	26	20	16
	30	60	3522	1435	1739	2933	63	49	33	24	20
	40	85	4989	2033	1838	3531	44	59	39	29	24
	50	115	6750	2750	1958	4247	33	71	47	35	28
2000	20	36	2113	860	2143	2860	140	51	34	26	20
	30	60	3522	1435	2239	3433	84	61	41	31	25
	40	85	4989	2033	2338	4031	59	72	48	36	29
	50	115	6750	2750	2458	4747	44	85	57	42	34

PERFORMANCE AND MATCHING TABLES FOR BV26 BRAZED PLATE HEAT EXCHANGER

Primary (55-50)°C | Secondary (12-48)°C | Primary side pressure drop: 40 kPa | Secondary side pressure drop: 20 kPa

Capacity L	BV26 Plates No.	Power kW	Primary flow L/h	Continuos production L/h	Production first 10' L	Production first 60' L	Recovery time minutes	NUMBER OF BATHROOMS / SHOWERS			
								Apartments	Hotels	Seasonal hotels	Sport facilities
200	20	10	1752	239	240	439	50	5	4	3	2
	30	17	2979	406	268	606	30	8	5	4	3
	40	23	4030	549	292	749	22	9	6	5	4
	50	32	5607	764	327	964	16	12	8	6	5
300	20	10	1752	239	340	539	75	7	4	3	3
	30	17	2979	406	368	706	44	9	6	4	4
	40	23	4030	549	392	849	33	11	7	5	4
	50	32	5607	764	427	1064	24	13	9	7	5
500	20	10	1752	239	540	739	126	10	7	5	4
	30	17	2979	406	568	906	74	13	8	6	5
	40	23	4030	549	592	1049	55	15	10	7	6
	50	32	5607	764	627	1264	39	18	12	9	7
800	20	10	1752	239	840	1039	201	15	10	8	6
	30	17	2979	406	868	1206	118	18	12	9	7
	40	23	4030	549	892	1349	87	20	13	10	8
	50	32	5607	764	927	1564	63	23	15	12	9
1000	20	10	1752	239	1040	1239	251	19	13	10	8
	30	17	2979	406	1068	1406	148	22	15	11	9
	40	23	4030	549	1092	1549	109	24	16	12	10
	50	32	5607	764	1127	1764	78	28	18	14	11
1500	20	10	1752	239	1540	1739	377	29	19	14	12
	30	17	2979	406	1568	1906	222	32	21	16	13
	40	23	4030	549	1592	2049	164	34	23	17	14
	50	32	5607	764	1627	2264	118	38	25	19	15
2000	20	10	1752	239	2040	2239	502	40	27	20	16
	30	17	2979	406	2068	2406	295	43	29	21	17
	40	23	4030	549	2092	2549	218	46	30	23	18
	50	32	5607	764	2127	2764	157	49	33	25	20

PRSH-C



**HOW TO ORDER**

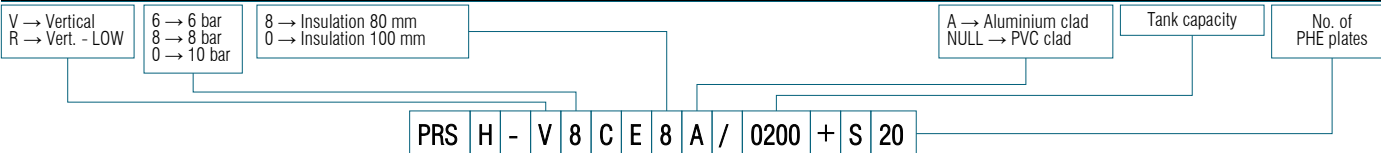

**ACCESSORIES & SPARE PARTS**

**ITEM**

*PART.NO*

**CERAMFLON ENAMELLED STEEL STORAGE TANKS**

THERMOMETER Ø65 mm   L=50 mm   (0÷120)°C	TERMOMETRO-D65_S
THERMOMETER Ø100 mm   L=150 mm   (0÷120)°C	TERMOMETRO-D100
PROBE SOCKET Ø½" L=150 mm   Ø <sub>int</sub> 10 mm	POZZETTO_L
THERMOSTAT Ø½" (0÷90)°C	TERMOSTATO
ELECTRONIC ANODE KIT 200÷500 L	ANODE012X380_P
ELECTRONIC ANODE KIT 800-1000 L	ANODE012X430_P
ELECTRONIC ANODE KIT 1500 - 2000 L	ANODE012X430X2_P



**BRAZED PLATE HEAT EXCHANGER BV 26**

BRAZED PLATE HEAT EXCHANGER BV 26   20 PLATES	BV026/020-H
BRAZED PLATE HEAT EXCHANGER BV 26   30 PLATES	BV026/030-H
BRAZED PLATE HEAT EXCHANGER BV 26   40 PLATES	BV026/040-H
BRAZED PLATE HEAT EXCHANGER BV 26   50 PLATES	BV026/050-H
NON-REMOVABLE THERMAL AND ANTI-CONDENSATION INSULATION (20 plates)	ISOLBV026AT-20
NON-REMOVABLE THERMAL AND ANTI-CONDENSATION INSULATION (30 plates)	ISOLBV026AT-30
NON-REMOVABLE THERMAL AND ANTI-CONDENSATION INSULATION (40 plates)	ISOLBV026AT-40
NON-REMOVABLE THERMAL AND ANTI-CONDENSATION INSULATION (50 plates)	ISOLBV026AT-50



**INSPECTION MANHOLE CLOSING PLATE**

Diameter <i>Internal × External</i> mm	Capacity L	CERAMFLON enamelled blind plate  <i>Part No.</i>	EPDM gaskets without cross bar  <i>Part No.</i>
220×300	200 ÷ 500	PIASTRAN300-C	GUGOMEPDM300X220ST
300×380	800 ÷ 2000	PIASTRAN380-C	GUGOMEPDM380X300ST

**1-PHASE & 3-PHASE IMMERSION ELECTRIC HEATER - STAINLESS STEEL 316L TUBES**  
Threaded plug 1.1/2" with brass adapter 1.1/2" to 2" | Aluminium box IP54 | V220/1-V240/1 or V400/3

Capacity Watt	Capacity/L matching L	Length mm	Volt mm	Plug type mm	2-THERMOSTAT Temperature regulation & overheating protection <i>PART NO.</i>
2000	200 ÷ 2000	310	220/1	SHUKO	RES020-L310-6-M-BT
3000	200 ÷ 2000	350	240/1		RES030-L350-6-M-BT
5000	200 ÷ 2000	375	400/3	Not supplied	RES050-L375-6-T-BT
6000	200 ÷ 2000	435			RES060-L435-6-T-BT
9000	500 ÷ 2000	610			RES090-L610-6-T-BT
10000	500 ÷ 2000	670			RES100-L670-6-T-BT
12000	800 ÷ 2000	730			RES120-L727-6-T-BT
15000	1500 ÷ 5000	870	RES150-L870-6-T-BT		



1-PHASE



3-PHASE

### PROTECTIVE TREATMENTS FOR CARBON STEEL TANKS

#### CERAMFLON enamelling

The "CERAMFLON" anti-corrosion treatment is an innovative system for the protection of the metallic walls which has been introduced by the recent developments in the studies on resins, guaranteeing hygiene and many other qualities:

- it is inert and insensitive corrosion thanks to its considerable resistance to ageing;
- it is water-repellent and impermeable to steam and moisture;
- it has a practically zero absorption of humidity and the stability is maintained both at high and low temperatures, so they can withstand even very high thermal excursions;
- it has a high impact resistance and a very low friction coefficient, which avoids large and hazardous adherence phenomena which, in the majority of cases, can be attributed to limescale;
- it has a low dielectric constant which is maintained at variations in operating temperatures.

The application of the resins using triboelectric guns, carried out after careful cleaning of the support, is consolidated on the product after baking in an oven at 200°C.

## CATHODIC PROTECTION

The corrosion of a metal structure occurs mainly in areas in which there is the passage of current (oxidation-reduction process) from the structure towards the outside (water or gas) causing a dissolution of the structure itself.

#### Cathodic protection by means of electronic impressed current system.

As an alternative to the galvanic system (coupling of materials with different potentials) there is a protection method which consists in applying an equal and opposite continuous current to the metallic structure to be protected, neutralising the voltages formed inside the tank.

Thanks to the modern techniques there is an innovative electronic system of cathodic protection with continuous impressed current.

The main advantages are:

- active protection by means of impressed currents from the outside;
- excellent flexibility of operation in order to adhere to the changeable internal coating conditions and the mass of water;

reduction of maintenance costs due to the permanent protection of the system



**INSULATIONS**

Insulating material	Removable	Thickness	Density	Thermal conductivity coefficient at 45°C	Operating temperature	Fire reaction class Euroclass EN13501-1
PLFH High Density Polyester fibre	✓	100 mm	25 kg/m <sup>3</sup>	$\lambda = 0,034 \text{ W/mK}$	Amb. / +99°C	B-s2, d0
Hard foam Polyurethane injected	✗	80 mm	40÷42 kg/m <sup>3</sup>	$\lambda = 0,019 \text{ W/mK}$	-10°C / +99°C	F

**PLFH / PLF – Polyester fibre**

- 100% recyclable
- Environmental friendly
- Lightweight
- Self-supporting
- Fire-retardant
- Rot-proof
- Resistant to mould, bacteria or rodents
- Hypoallergenic
- Water repellent



The raw materials consist of polyester fibres and heat-bonded co-polyester fibres, coming mainly from the recycling of plastic bottles obtained from urban waste collection.

It does not contain substances harmful to humans, may be handled and installed in complete safety, does not release powder, is hypoallergenic and cannot be attacked by microorganisms, mould and insects.

PLFH/PLF is a heat insulating product considered environmentally sustainable, even though it is not of natural origin: it is in fact recyclable and the quantity of embodied energy necessary to obtain it is extremely low.

The composition of the polyester fibre makes it an insulating material with an extremely low heat dispersion and its characteristics remain unaltered over time as it is not affected by humidity and its compact, flexible and resistant original structure is not modified.

Thanks to its characteristics, PLFH/PLF is an insulating material with the highest performance characteristics, which allows the requirements set by the severest technical standards to be satisfied, guaranteeing the maximum environmental compatibility for its entire life cycle.

**Hard foam Polyurethane**

Thermal and anti-condensation insulation made of hard closed cell polyurethane foam (PU), free from CFC and HCFC.

It is available in various thickness and can be injected directly to the shell of the tank to prevent it from condensation and provide the lower thermal dispersion. For some sizes it is pre-formed into half-shells to ease the insulation removal in case the tank has to pass through narrow doors.

**CLADDINGS**

**PVC**

External cladding made of coloured PVC with hinge closing, suitable for installations in locations protected against adverse weather conditions. The standard colours of each product are indicated in their construction characteristics, but different colours can be requested for each model as shown in the following table.



**ITEM**

	PART NO.
PVC CLADDING YERLLOW RAL1023	COVER-RAL1023
PVC CLADDING OREANGE RAL2004	COVER-RAL2004
PVC CLADDING RED RAL3000	COVER-RAL3000
PVC CLADDING BLUE RAL5015	COVER-RAL5015
PVC CLADDING WHITE RAL9016	COVER-RAL9016
PVC CLADDING LIGHT GREY RAL7035	COVER-RAL7035
PVC CLADDING DARK GREY RAL7024	COVER-RAL7024
PVC CLADDING BLACK RAL9004	COVER-RAL9004

**ALUMINIUM**

External cladding made of embossed aluminium sheeting suitable also for outdoor installations. The insulations made with this type of cladding consist of panels joined together by means of rivets and extruded aluminium slats with an exclusive design, specifically designed to facilitate assembly even directly at the installation site.

The coverings and flange covers made of same material securely anchored to the insulation guarantee the same levels of quality in terms of duration and outside appearance and do not risk being damaged by the wind and adverse weather conditions.





[www.pacetti.it](http://www.pacetti.it)



MADE IN ITALY

**PACETTI S.r.l.**

Via G. Marconi, 240/242

44122 - Ferrara - ITALY

Tel. +39 0532 774066

Fax +39 0532 773835

[info@pacetti.it](mailto:info@pacetti.it)