

dal 1968



SCAMBIATORI - BOLLITORI - SERBATOI



TAH-C - TA-C



ENAMELLED STEEL DHW STORAGE TANK
WITH INSPECTION OPENING
AND ELECTRONIC ANODE

ENAMELLED STEEL DHW STORAGE TANK WITH INSPECTION OPENING & ELECTRONIC ANODE

Storage tank made of CERAMFLON enamelled steel, equipped with inspection opening and electronic anode.

Designed to increase the availability of Domestic Water heated from external sources, increase the thermal inertia and considerably reduce the heat loss thanks to the excellent insulation properties.

The inspection opening allows checking and cleaning the tank inside, to get maximum hygiene levels.

Available from 200 to 5000 litre capacities and over, these tanks can also be manufactured in vertical-low and vertical extra-low versions, to allow them to be installed in all those circumstances where the standard dimension does not fit the available height.

The possibility of selecting between different operating pressure (up to 10 bar) and the availability of external cladding with PVC or aluminium finishing, makes this DHW storage tank range suitable for any kind of installation.

The protection from galvanic currents through the electronic anodes given as standard, allow to save the management costs due to the frequent control and replacement of the traditional magnesium anodes, ensuring greater reliability and duration over time.

CONSTRUCTION

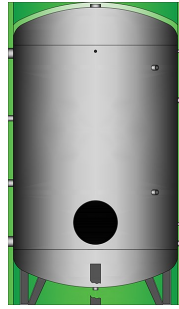

TAH-C | TA-C

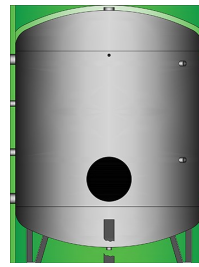

TAH-RC | TA-RC



TA-XC

TANK MATERIAL	Carbon steel	Carbon steel	Carbon steel
INTERNAL SURFACE TREATMENT	CERAMFLON enamel	CERAMFLON enamel	CERAMFLON enamel
EXTERNAL SURFACE TREATMENT	Anti-rust primer	Anti-rust primer	Anti-rust primer
CAPACITY	200 ÷ 5000 L	1500 ÷ 5000 L	3000 ÷ 5000 L
VERSIONY	Vertical	Vertical LOW	Vertical EXTRA LOW
CONNECTIONS TYPE	Threaded	Threaded	Threaded
INSULATION 200 ÷ 500 L	Hard foam PU injected 80 mm	—	—
INSULATION 800 ÷ 2000 L	PLFH (HD Polyester fibre) 100 mm	PLFH (HD Polyester fibre) 100 mm	—
INSULATION 2500 ÷ 5000 L	PLF (Polyester fibre) 50 mm	PLF (Polyester fibre) 50 mm	PLF (Polyester fibre) 50 mm
CLADDING	<ul style="list-style-type: none"> • PVC Yellow RAL1023 • Aluminium 	<ul style="list-style-type: none"> • PVC Yellow RAL1023 • Aluminium 	<ul style="list-style-type: none"> • PVC Yellow RAL1023 • Aluminium
ANODE	ELECTRONIC	ELECTRONIC	ELECTRONIC
STANDARD ACCESSORIES	THERMOMETER	THERMOMETER	THERMOMETER

PRODUCT FICHE - Reg. 812/2013 supplementing Directive 2010/30/EU & Reg 814/2013 implementing Directive 2009/125/EC

		Capacity		200	300	500	800	1000	1500	2000
TAH-C	Energy class			B	B	B	C	C	C	C
	Standing loss	S	W	55	64	81	133	144	168	190
	Storage volume	V	L	193	296	505	796	920	1491	1998
TAH-RC	Energy class								C	C
	Standing loss	S	W						167	185
	Storage volume	V	L						1529	1973

WORKING CONDITIONS

		Capacity		200	300	500	800	1000	1500	2000	2500	3000	4000	5000
Tank operating pressure	bar	ATM ÷ 8	ATM ÷ 8	ATM ÷ 8	ATM ÷ 8	ATM ÷ 8	ATM ÷ 8	ATM ÷ 6	ATM ÷ 6	ATM ÷ 6	ATM ÷ 6	ATM ÷ 6	ATM ÷ 6	ATM ÷ 6
Tank operating temperature	°C	AMB ÷ 85	AMB ÷ 85	AMB ÷ 85	AMB ÷ 85	AMB ÷ 85	AMB ÷ 85	AMB ÷ 85	AMB ÷ 85	AMB ÷ 85	AMB ÷ 85	AMB ÷ 85	AMB ÷ 85	AMB ÷ 85

REGULATORY COMPLIANCE

ErP - Reg. 812/2013 e Reg. 814/2013 | CE

European Pressure Equipment Directive (PED) 2014/68/UE | Sound Engineering Practice - excluded from CE marking - Art. 4.3

D.M. 174/04 | Suitable for contact with water for human consumption

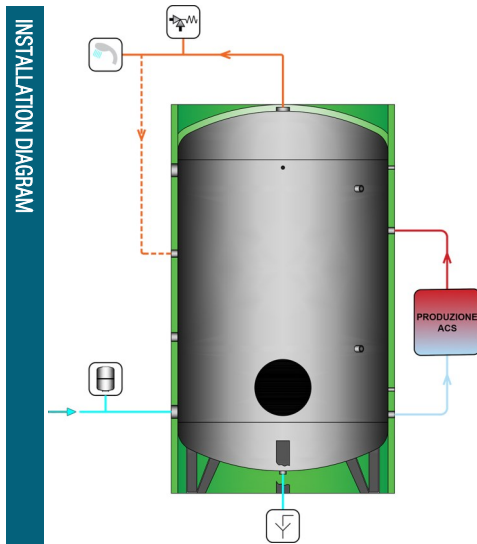
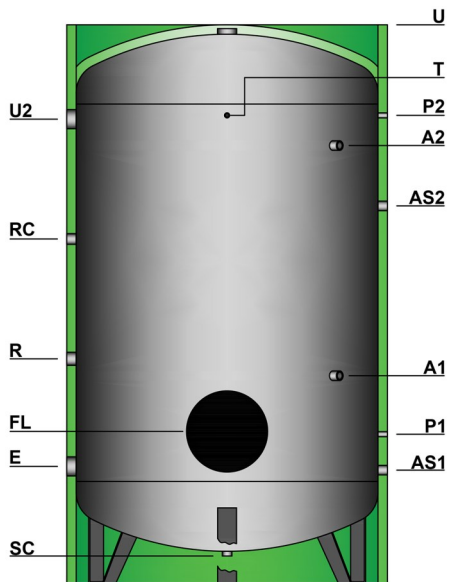

The proposed diagrams are purely by way of example.

GENERAL CHARACTERISTICS TAH-C | TA-C

	Capacity	200	300	500	800	1000	1500
DIMENSIONS							
Diameter without insulation	mm	450	550	650	800	800	950
Diameter with insulation	mm	610	710	810	1000	1000	1150
Overall height	mm	1515	1554	1844	1950	2200	2510
Overturning height with without insulation	mm	1577 —	1638 —	1936 —	2114 1933	2316 2166	2654 2502

CONNECTIONS							
E Cold water supply	mm Ø	355 1"½	369 1"½	384 1"½	420 2"	420 2"	465 2"½
U DHW return	mm Ø	1515 1"½	1554 1"½	1844 1"½	1950 2"	2200 2"	2510 2"½
U2 DHW return	mm Ø	—	—	—	—	—	—
RC Recirculation	mm Ø	1005 1"½	1019 1"½	1259 1"½	1370 1"½	1405 1"½	1580 1"½
R Immersion electric heater	mm Ø	775 2"	789 2"	804 2"	1010 2"	1010 2"	1035 2"
P1 Sensor	mm Ø	475 ½"	489 ½"	504 ½"	610 ½"	610 ½"	635 ½"
P2 Sensor	mm Ø	1255 ½"	1269 ½"	1534 ½"	1550 ½"	1700 ½"	2125 ½"
T Thermometer	mm Ø	1255 ½"	1269 ½"	1534 ½"	1550 ½"	1800 ½"	2125 ½"
A1 Anode	mm Ø	855 ½"	869 ½"	884 ½"	920 ½"	920 ½"	945 ½"
A2 Anode	mm Ø	—	—	—	—	—	1965 ½"
AS1 Spare	mm Ø	355 1"¼	369 1"¼	384 1"¼	420 1"¼	420 1"¼	445 1"¼
AS2 Spare	mm Ø	1155 1"¼	1169 1"¼	1184 1"¼	1220 1"¼	1820 1"¼	1845 1"¼
FL Inspection opening	mm Ø	475 220×300	489 220×300	504 220×300	610 300×380	610 300×380	635 300×380
SC Drain	mm Ø	145 1"¼	134 1"¼	124 1"¼	120 1"¼	120 1"¼	160 1"¼

EMPTY WEIGHTS							
Empty weight	kg	60	70	100	140	150	210

	Capacity	2000	2500	3000	4000	5000
DIMENSIONS						
Diameter without insulation	mm	1100	1200	1250	1400	1600
Diameter with insulation	mm	1300	1300	1350	1500	1700
Overall height	mm	2535	2590	2790	2869	2960
Overturning height with without insulation	mm	2712 2541	2773 2600	2990 2800	3088 2883	3232 2982

CONNECTIONS						
E Cold water supply	mm Ø	485 2"½	530 3"	525 3"	559 3"	620 3"
U DHW return	mm Ø	2535 2"½	2590 3"	2790 3"	2869 3"	2960 3"
U2 DHW return	mm Ø	—	—	—	2399 3"	2460 3"
RC Recirculation	mm Ø	1600 1"½	1645 1"¼	1730 1"½	1764 1"½	1825 1"½
R Immersion electric heater	mm Ø	1055 2"	1100 2"	1095 2"	1129 2"	1190 2"
P1 Sensor	mm Ø	655 ½"	700 ½"	1005 ½"	729 ½"	790 ½"
P2 Sensor	mm Ø	2095 ½"	2190 ½"	2225 ½"	2419 ½"	2480 ½"
T Thermometer	mm Ø	2095 ½"	2190 ½"	2385 ½"	2419 ½"	2480 ½"
A1 Anode	mm Ø	965 ½"	1010 ½"	1005 ½"	1039 ½"	1100 ½"
A2 Anode	mm Ø	1935 ½"	2030 ½"	2225 ½"	2259 ½"	2320 ½"
AS1 Spare	mm Ø	465 1"¼	510 1"¼	505 1"¼	539 1"¼	600 1"¼
AS2 Spare	mm Ø	1865 1"¼	1910 1"¼	1905 1"¼	1939 1"¼	2000 1"¼
FL Inspection opening	mm Ø	655 300×380	700 300×380	695 300×380	729 350×430	790 350×430
SC Drain	mm Ø	145 1"¼	160 1"¼	150 1"¼	139 1"¼	170 1"¼

EMPTY WEIGHTS						
Empty weight	kg	270	340	370	495	585

Note: All the measurements of the connections are considered "from the ground". The thread are female GAS type, unless otherwise specified. The tanks higher than 2200mm are packaged horizontally. In this case, should the cladding be Aluminium type, it will come disassembled to avoid transportation damages.

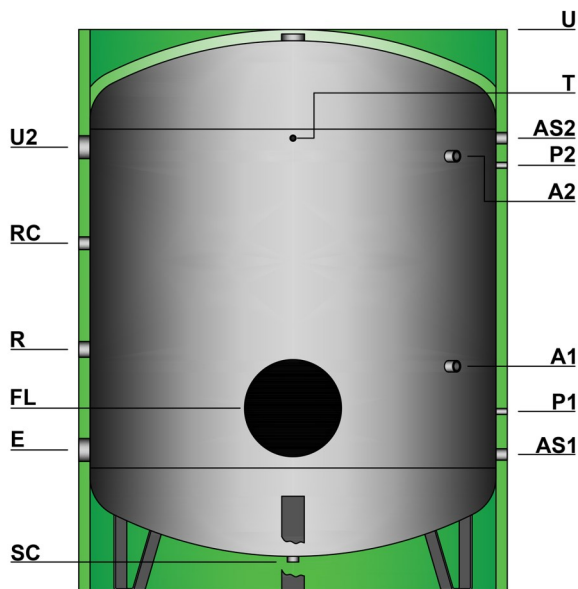

INSTALLATION DIAGRAM

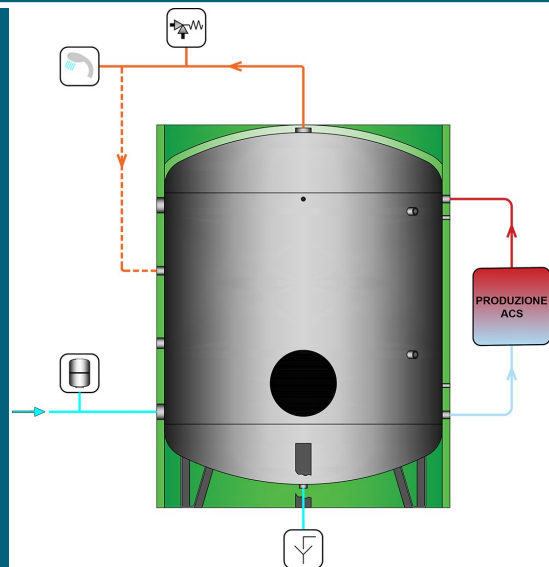

The proposed diagrams are purely by way of example.

GENERAL CHARACTERISTICS TAH-RC | TA-RC

	Capacity	1500	2000	2500	3000	4000	5000
DIMENSIONS							
Diameter without insulation	mm	1100	1250	1400	1400	1600	1800
Diameter with insulation	mm	1300	1450	1500	1500	1700	1900
Overall height	mm	2015	2039	2119	2369	2460	2483
Overturning height with without insulation	mm	2237 2019	2310 2059	2410 2237	2632 2469	2781 2582	2874 2639

CONNECTIONS

E Cold water supply	mm Ø	485 2"½	504 2"½	559 3"	559 3"	620 3"	622 3"
U DHW return	mm Ø	2015 2"½	2039 2"½	2119 3"	2369 3"	2460 3"	2483 3"
U2 DHW return	mm Ø	—	—	—	—	1960 3"	1962 3"
RC Recirculation	mm Ø	1235 1"½	1254 1"½	1309 1"½	1474 1"½	1535 1"½	1537 1"½
R Immersion electric heater	mm Ø	865 2"	884 2"	939 2"	1004 2"	1065 2"	1067 2"
P1 Sensor	mm Ø	655 ½"	674 ½"	729 ½"	729 ½"	790 ½"	792 ½"
P2 Sensor	mm Ø	1595 ½"	1564 ½"	1669 ½"	1819 ½"	1880 ½"	1882 ½"
T Thermometer	mm Ø	1595 ½"	1564 ½"	1669 ½"	1939 ½"	2000 ½"	2002 ½"
A1 Anode	mm Ø	870 ½"	864 ½"	944 ½"	929 ½"	990 ½"	992 ½"
A2 Anode	mm Ø	1535 ½"	1504 ½"	1609 ½"	1859 ½"	1920 ½"	1922 ½"
AS1 Spare	mm Ø	465 1"¼	484 1"¼	539 1"¼	539 1"¼	600 1"¼	602 1"¼
AS2 Spare	mm Ø	1265 1"¼	1284 1"¼	1339 1"¼	1939 1"¼	2000 1"¼	2002 1"¼
FL Inspection opening	mm Ø	655 300×380	674 300×380	729 300×380	729 300×380	790 350×430	792 350×430
SC Drain	mm Ø	145 1"¼	129 1"¼	139 1"¼	139 1"¼	170 1"¼	170 1"¼

EMPTY WEIGHTS

Empty weight	kg	225	285	395	430	470	610
--------------	----	-----	-----	-----	-----	-----	-----

Note: All the measurements of the connections are considered "from the ground". The thread are female GAS type, unless otherwise specified. The tanks higher than 2200mm are packaged horizontally. In this case, should the cladding be Aluminium type, it will come disassembled to avoid transportation damages.

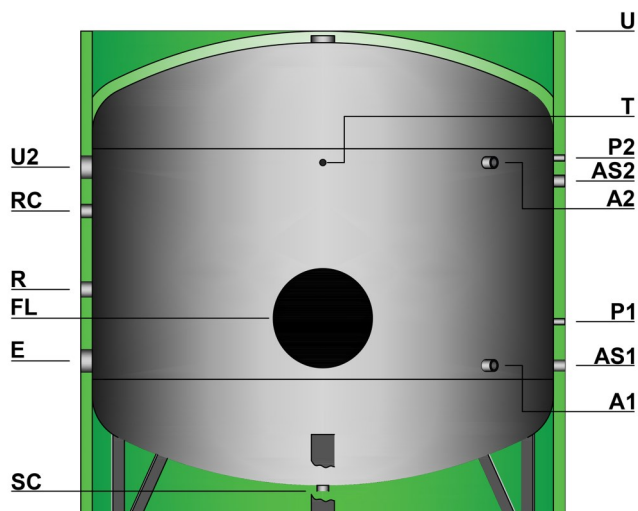

INSTALLATION DIAGRAM

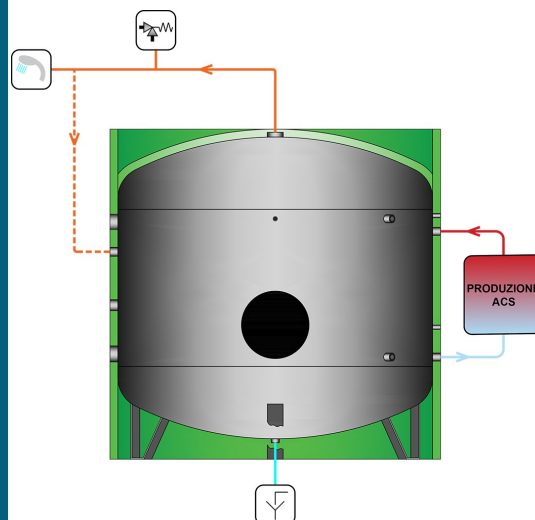

The proposed diagrams are purely by way of example.

GENERAL CHARACTERISTICS TA-XC

	Capacity	3000	4000	5000
DIMENSIONS				
Diameter without insulation	mm	1500	1700	2000
Diameter with insulation	mm	1600	1800	2100
Overall height	mm	2130	2190	2100
Overturning height with without insulation	mm	2452 2254	2579 2348	2628 2341
CONNECTIONS				
E Cold water supply	mm Ø	560 3"	590 3"	670 3"
U DHW return	mm Ø	2130 3"	2190 3"	2100 3"
U2 DHW return	mm Ø	1650 3"	1680 3"	1510 3"
RC Recirculation	mm Ø	1340 1"½	1370 1"½	1320 1"½
R Immersion electric heater	mm Ø	1030 2"	1060 2"	980 2"
P1 Sensor	mm Ø	730 ½"	760 ½"	840 ½"
P2 Sensor	mm Ø	1670 ½"	1700 ½"	1530 ½"
T Thermometer	mm Ø	1670 ½"	1700 ½"	1530 ½"
A1 Anode	mm Ø	540 ½"	570 ½"	650 ½"
A2 Anode	mm Ø	1590 ½"	1620 ½"	1530 ½"
AS1 Spare	mm Ø	540 1"¼	570 1"¼	650 1"¼
AS2 Spare	mm Ø	1340 1"¼	1370 1"¼	1450 1"¼
FL Inspection opening	mm Ø	730 300×380	760 350×430	840 350×430
SC Drain	mm Ø	130 1"¼	130 1"¼	130 1"¼
EMPTY WEIGHTS				
Empty weight	kg	380	515	660

Note: All the measurements of the connections are considered "from the ground". The thread are female GAS type, unless otherwise specified. The tanks higher than 2200mm are packaged horizontally. In this case, should the cladding be Aluminium type, it will come disassembled to avoid transportation damages.

HOW TO ORDER

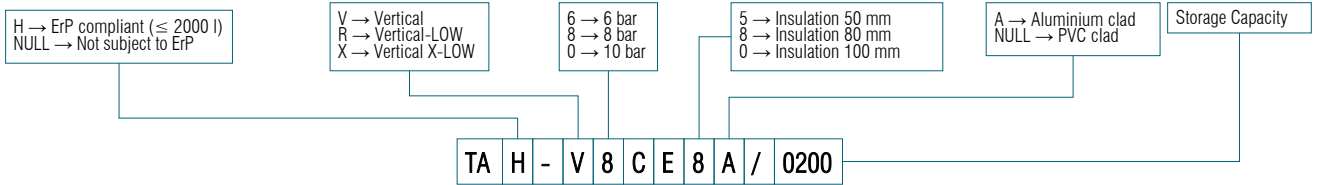

ACCESSORIES & SPARE PARTS

ITEM

ITEM	CODICE ARTICOLO			
THERMOMETER Ø65 mm L=150 mm (0÷120)°C	TERMOMETRO-D65_L		THERMOMETE	
THERMOMETER Ø100 mm L=150 mm (0÷120)°C	TERMOMETRO-D100			
PROBE SOCKET Ø½" L=150 mm Ø _{int} 10 mm	POZZETTO_L		PROBE SOCKET	
THERMOSTAT Ø½" (0÷90)°C	TERMOSTATO		THERMOSTAT	
ELECTRONIC ANODE KIT 200÷500 L	ANODE012X380_P			
ELECTRONIC ANODE KIT 800-1000 L	ANODE012X430_P			
ELECTRONIC ANODE KIT 1500÷5000 L	ANODE012X430X2_P		ELECTRONIC ANODE	

1-PHASE & 3-PHASE IMMERSION ELECTRIC HEATER - STAINLESS STEEL 316L TUBES
Threaded plug 1.1/2" with brass adapter 1.1/2" to 2" | Aluminium box IP54 | V220/1-V240/1 or V400/3

Capacity	Capacity/L matching	Length	Volt	Plug type	2-THERMOSTAT Temperature regulation & overheating protection	
Watt	L	mm	mm	mm	PART NO.	
2000	200 ÷ 5000	310	220/1	SHUKO	RES020-L310-6-M-BT	
3000	200 ÷ 5000	350	240/1		RES030-L350-6-M-BT	
5000	200 ÷ 5000	375			RES050-L375-6-T-BT	
6000	200 ÷ 5000	435			RES060-L435-6-T-BT	
9000	500 ÷ 5000	610	400/3	Not supplied	RES090-L610-6-T-BT	
10000	500 ÷ 5000	670			RES100-L670-6-T-BT	
12000	800 ÷ 5000	730			RES120-L727-6-T-BT	
15000	1500 ÷ 5000	870			RES150-L870-6-T-BT	

INSPECTION MANHOLE

Diameter Internal×External mm	Capacity L	Blind closing plate made of CERAMFLON enamelled steel Code	EPDM gasket without cross bar Code
220×300	200 ÷ 500	PIASTRAN300-C	GUGOMEPDM300X220ST
300×380	800 ÷ 3000	PIASTRAN380-C	GUGOMEPDM380X300ST
350×430	4000-5000	PIASTRAN430-C	GUGOMEPDM430X350ST

PROTECTIVE TREATMENTS FOR CARBON STEEL TANKS

CERAMFLON enamelling

The "CERAMFLON" anti-corrosion treatment is an innovative system for the protection of the metallic walls which has been introduced by the recent developments in the studies on resins, guaranteeing hygiene and many other qualities:

- it is inert and insensitive corrosion thanks to its considerable resistance to ageing;
- it is water-repellent and impermeable to steam and moisture;
- it has a practically zero absorption of humidity and the stability is maintained both at high and low temperatures, so they can withstand even very high thermal excursions;
- it has a high impact resistance and a very low friction coefficient, which avoids large and hazardous adherence phenomena which, in the majority of cases, can be attributed to limescale;
- it has a low dielectric constant which is maintained at variations in operating temperatures.

The application of the resins using triboelectric guns, carried out after careful cleaning of the support, is consolidated on the product after baking in an oven at 200°C.

CATHODIC PROTECTION

The corrosion of a metal structure occurs mainly in areas in which there is the passage of current (oxidation-reduction process) from the structure towards the outside (water or gas) causing a dissolution of the structure itself.

Cathodic protection by means of electronic impressed current system.

As an alternative to the galvanic system (coupling of materials with different potentials) there is a protection method which consists in applying an equal and opposite continuous current to the metallic structure to be protected, neutralising the voltages formed inside the tank.

Thanks to the modern techniques there is an innovative electronic system of cathodic protection with continuous impressed current.

The main advantages are:

- active protection by means of impressed currents from the outside;
- excellent flexibility of operation in order to adhere to the changeable internal coating conditions and the mass of water;
- reduction of maintenance costs due to the permanent protection of the system.



INSULATIONS

Insulating material	Removable	Thickness	Density	Thermal conductivity coefficient at 45°C	Operating temperature	Fire reaction class Euroclass EN13501-1
PLF Polyester fibre	✓	50 mm	20 kg/m ³	$\lambda = 0,037 \text{ W/mK}$	Amb. / +99°C	B-s2, d0
PLFH High Density Polyester fibre	✓	100 mm	25 kg/m ³	$\lambda = 0,034 \text{ W/mK}$	Amb. / +99°C	B-s2, d0
Hard foam Polyurethane injected	✗	80 mm	40÷42 kg/m ³	$\lambda = 0,019 \text{ W/mK}$	-10°C / +99°C	F

PLFH / PLF – Polyester fibre

- 100% recyclable
- Environmental friendly
- Lightweight
- Self-supporting
- Fire-retardant
- Rot-proof
- Resistant to mould, bacteria or rodents
- Hypoallergenic
- Water repellent



The raw materials consist of polyester fibres and heat-bonded co-polyester fibres, coming mainly from the recycling of plastic bottles obtained from urban waste collection.

It does not contain substances harmful to humans, may be handled and installed in complete safety, does not release powder, is hypoallergenic and cannot be attacked by microorganisms, mould and insects.

PLFH/PLF is a heat insulating product considered environmentally sustainable, even though it is not of natural origin: it is in fact recyclable and the quantity of embodied energy necessary to obtain it is extremely low.

The composition of the polyester fibre makes it an insulating material with an extremely low heat dispersion and its characteristics remain unaltered over time as it is not affected by humidity and its compact, flexible and resistant original structure is not modified.

Thanks to its characteristics, PLFH/PLF is an insulating material with the highest performance characteristics, which allows the requirements set by the severest technical standards to be satisfied, guaranteeing the maximum environmental compatibility for its entire life cycle.

Hard foam Polyurethane

Thermal and anti-condensation insulation made of hard closed cell polyurethane foam (PU), free from CFC and HCFC.

It is available in various thickness and can be injected directly to the shell of the tank to prevent it from condensation and provide the lower thermal dispersion. For some sizes it is pre-formed into half-shells to ease the insulation removal in case the tank has to pass through narrow doors.

CLADDINGS

**PVC**

External cladding made of coloured PVC with hinge closing, suitable for installations in locations protected against adverse weather conditions. The standard colours of each product are indicated in their construction characteristics,

but different colours can be requested for each model as shown in the following table.

In the personalised TLR storage tanks the choice of the alternative colour is free of cost and does not incur any surcharge.

ITEM**PART NUMBER**

PVC COVER YELLOW RAL1023	COVER-RAL1023
PVC COVER ORANGE RAL2004	COVER-RAL2004
PVC COVER RED RAL3000	COVER-RAL3000
PVC COVER BLUE RAL5015	COVER-RAL5015
PVC COVER WHITE RAL9016	COVER-RAL9016
PVC COVER LIGHT GREY RAL7035	COVER-RAL7035
PVC COVER DARK GREY RAL7024	COVER-RAL7024
PVC COVER BLACK RAL9004	COVER-RAL9004

**ALUMINIUM**

External cladding made of embossed aluminium sheeting suitable also for outdoor installations. The insulations made with this type of cladding consist of panels joined together by means of rivets and extruded aluminium slats

with an exclusive design, specifically designed to facilitate assembly even directly at the installation site.

The coverings and flange covers made of same material securely anchored to the insulation guarantee the same levels of quality in terms of duration and outside appearance and do not risk being damaged by the wind and adverse weather conditions.

This page is left intentionally blank.

www.pacetti.it



MADE IN ITALY

PACETTI S.r.l.

Via G. Marconi, 240/242

44122 - Ferrara - ITALY

Tel. +39 0532 774066

Fax +39 0532 773835

info@pacetti.it