

dal 1968



SCAMBIATORI - BOLLITORI - SERBATOI



BKPN1

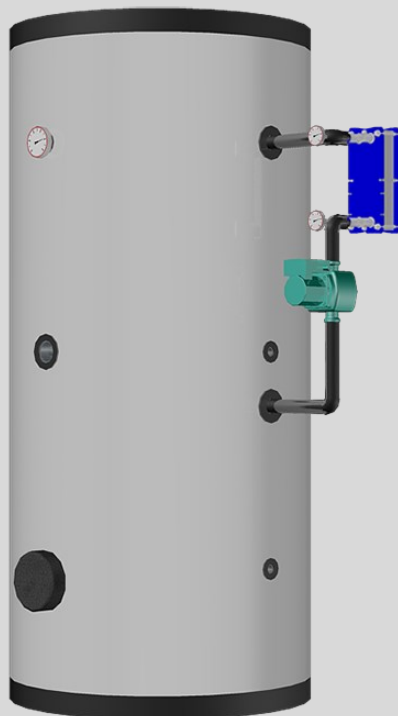

DHW CALORIFIER WITH SINGLE OR TWIN BUILT-IN, OVERSIZED SPIRAL COILS FOR HEAT PUMP PRIMARY AND EXTERNAL GASKETED PLATE HEAT EXCHANGER KIT

Water heaters designed for domestic hot water (DHW) production and storage. They are compatible with heat pumps and any other energy source. **BKPN** range tanks are equipped with fixed spiral coils to maximise the heating exchange surface area in relation to storage capacity.

The **BKPN1** model is equipped with an oversized single spiral coil, and its high heat exchange surface allows for optimal efficiency when connected to a heat pump.

The **BKPN2** model is equipped with an oversized single spiral coil for connection to the heat pump, and a second coil for connection to an additional energy source, either conventional or renewable, serving as a booster to the heat pump or a separate power supply.

The **BKPN1** series is equipped with an external plate heat exchanger kit that allows a third heating source to be managed simultaneously. Combining the high performance of **BKPN1** water heaters with the external kit, which comprises a gasketed plate heat exchanger, a stainless steel circulator and ready-to-install hydraulic connection pipework, makes the **BKPN1** series suitable for use in demanding applications where heating sources have different power and thermal efficiencies. Thanks to the external gasketed plate heat exchanger, all available energy sources can be exploited and conveyed to one storage unit for maximum efficiency and to save space at installation sites.

Thermal insulation is an effective solution for ensuring minimal heat loss, thereby maintaining a constant temperature of the water stored inside the tank. This results in a reduced number of starts of connected heating generators, leading to savings in operating costs and increased reliability. Insulations are factory-made, and the external cladding can be selected from either a technical fabric, suitable for indoor installation only, or an embossed aluminium sheet, suitable for both indoor and outdoor installation. **BKPN** range tanks are available in two options: glass-lined carbon steel (**BKPN...-V**), which complies with DIN4753.3, and stainless steel AISI 316L (**BKPN...-X**), which meets the most demanding quality requirements.

CONSTRUCTION

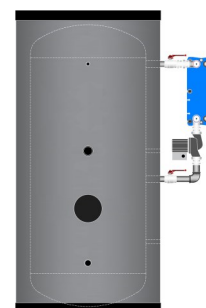
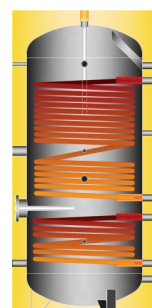
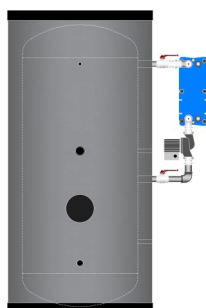
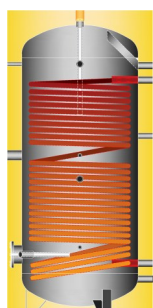

BKPN1-V

BKPN1-X

BKPN2-V

BKPN2-X

WATER HEATER				
TANK MATERIAL	Carbon Steel	Stainless Steel AISI 316L	Carbon Steel	Stainless Steel AISI 316L
SPIRAL COIL MATERIAL	Carbon steel (glass-lined externally)	Stainless Steel AISI 316L	Carbon steel (glass-lined externally)	Stainless Steel AISI 316L
INT. SURFACE STEEL TREATMENT	Glass-lining (DIN 4753.3)	Pickling and passivation	Glass-lining (DIN 4753.3)	Pickling and passivation
EXT. SURFACE STEEL TREATMENT	Antirust primer	Pickling and passivation	Antirust primer	Pickling and passivation
CAPACITY	200 ÷ 2000 L	200 ÷ 2000 L	300 ÷ 2000 L	300 ÷ 2000 L
VERSION	Vertical	Vertical	Vertical	Vertical
CONNECTION TYPE	Threaded	Threaded	Threaded	Threaded
INSULATION 200 ÷ 500 L	55 mm Hard foam polyurethane injected	55 mm Hard foam polyurethane injected	55 mm Hard foam polyurethane injected	55 mm Hard foam polyurethane injected
INSULATION 800 ÷ 2000 L	100 mm PLFH High density polyester fiber eco-friendly	100 mm PLFH High density polyester fiber eco-friendly	100 mm PLFH High density polyester fiber eco-friendly	100 mm PLFH High density polyester fiber eco-friendly
OUTER CLADDING	Light grey PVC - RAL7035	Light grey PVC - RAL7035	Light grey PVC - RAL7035	Light grey PVC - RAL7035
ANODE TYPE	Magnesium (factory fitted)	Electronic (on request)	Magnesium (factory fitted)	Electronic (on request)
ACCESSORIES (factory fitted)	Thermometer	Thermometer	Thermometer	Thermometer
EXTERNAL GASKETED PLATE HEAT EXCHANGER KIT				
GASKETED PHE MODEL	PK 43	PK 43	PK 43	PK 43
GASKETED PHE - PLATES MATERIAL	Stainless Steel AISI 316L	Stainless Steel AISI 316L	Stainless Steel AISI 316L	Stainless Steel AISI 316L
PIPEWORK MATERIAL	Galvanized steel	Stainless steel	Galvanized steel	Stainless steel
ACCESSORIES (factory fitted)	<ul style="list-style-type: none"> • PHE temp. gauges (in/out) • Thermostat • DHV circulator pump 	<ul style="list-style-type: none"> • PHE temp. gauges (in/out) • Thermostat • DHV circulator pump 	<ul style="list-style-type: none"> • PHE temp. gauges (in/out) • Thermostat • DHV circulator pump 	<ul style="list-style-type: none"> • PHE temp. gauges (in/out) • Thermostat • DHV circulator pump

REGULATORY COMPLIANCE

WATER HEATER	
European Pressure Equipment Directive (PED) 2014/68/EU SEP (Sound Engineering Practice) - exclusion from CE marking - Art. 4.3	
ErP - Reg. 812/2013 & Reg. 814/2013 (European Directive 2009/125/CE)	
D.M. 174/04 or Reg. (CE) 1935/04 Compatible with potable water	
EXTERNAL GASKETED PLATE HEAT EXCHANGER KIT	
European Pressure Equipment Directive (PED) 2014/68/EU SEP (Sound Engineering Practice) - exclusion from CE marking - Art. 4.3	
D.M. 174/04 or Reg. (CE) 1935/04 Compatible with potable water	

DHW CALORIFIER WITH BUILT-IN OVERSIZED SPIRAL COILS FOR HP PRIMARY AND EXTERNAL GASKETED PHE KIT

Energy efficiency class - Regulation EU 812/2013 & 814/2013 (European Directive 2009/125/CE)

			Capacity - L	200	300	500	800	1000	1500	2000
Energy efficiency class				C	C	C	C	C	C	C
BKPN1-V	Standing loss	S W		65	78	103	122	132	154	178
	Storage total volume	V L		193	256	447	752	864	1400	1904
Energy efficiency class				C	C	C	C	C	C	C
BKPN2-V	Standing loss	S W			79	104	124	132	155	179
	Storage total volume	V L			256	433	755	869	1424	1909
Energy efficiency class				C	C	C	C	C	C	C
BKPN1-X	Standing loss	S W		65	78	103	122	132	154	178
	Storage total volume	V L		193	256	447	752	864	1400	1904
Energy efficiency class				C	C	C	C	C	C	C
BKPN2-X	Standing loss	S W			79	104	124	132	155	179
	Storage total volume	V L			256	433	755	869	1424	1909

STANDARD WORKING CONDITIONS

			Capacity - L	200	300	500	800	1000	1500	2000
Working pressure	Glass-lined tank and galvanized steel pipework	bar		ATM ÷ 10	ATM ÷ 10	ATM ÷ 10	ATM ÷ 10	ATM ÷ 10	ATM ÷ 10	ATM ÷ 10
	Stainless steel tank and stainless steel pipework	bar		ATM ÷ 8	ATM ÷ 8	ATM ÷ 8	ATM ÷ 8	ATM ÷ 8	ATM ÷ 8	ATM ÷ 8
	Spiral coil	bar		ATM ÷ 10	ATM ÷ 10	ATM ÷ 10	ATM ÷ 10	ATM ÷ 10	ATM ÷ 10	ATM ÷ 10
	Gasketed Plate heat exchanger [primary side]	bar		ATM ÷ 16	ATM ÷ 16	ATM ÷ 16	ATM ÷ 16	ATM ÷ 16	ATM ÷ 16	ATM ÷ 16
Working temperature	Glass-lined tank and galvanized steel pipework	°C		AMB ÷ 95	AMB ÷ 95	AMB ÷ 95	AMB ÷ 95	AMB ÷ 95	AMB ÷ 95	AMB ÷ 95
	Stainless steel tank and stainless steel pipework	°C		AMB ÷ 99	AMB ÷ 99	AMB ÷ 99	AMB ÷ 99	AMB ÷ 99	AMB ÷ 99	AMB ÷ 99
	Spiral coil	°C		AMB ÷ 110	AMB ÷ 110	AMB ÷ 110	AMB ÷ 110	AMB ÷ 110	AMB ÷ 110	AMB ÷ 110
	Gasketed Plate heat exchanger [primary side]	°C		-10 ÷ 110	-10 ÷ 110	-10 ÷ 110	-10 ÷ 110	-10 ÷ 110	-10 ÷ 110	-10 ÷ 110

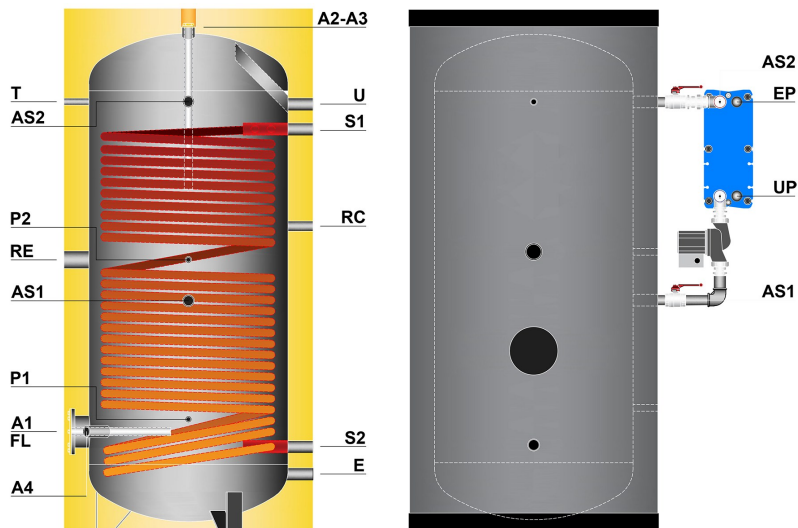

BKPN1-V GENERAL CHARACTERISTICS

	Capacity - L	200	300	500	800	1000	1500	2000
DIMENSIONS								
Diameter without insulation	mm	500	500	650	800	800	1000	1200
Diameter with insulation	mm	610	610	760	1000	1000	1200	1400
Maximum height	mm	1320	1640	1720	1854	2104	2265	2245
Overturning height with without insulation	mm	1460	1760	1890	2110 1840	2340 2090	2570 2270	2650 2280
CONNENCTIONS								
	H from ground Ø							
E Cold water inlet	mm Ø	150 1"	150 1"	185 1"	235 1"¼	235 1"¼	315 2"	445 2"
U Hot water outlet	mm Ø	1070 1"	1395 1"	1515 1"	1470 1"¼	1720 1"¼	1795 2"	1815 2"
RC Recirculation	mm Ø	770 1"	1050 1"	1095 1"	1050 1"	1230 1"¼	1300 1"½	1300 1"½
R Immersion electric heater	mm Ø	700 2"	955 2"	920 2"	935 2"	1095 2"	1165 2"	1160 2"
P1 Sensor	mm Ø	360 ½"	345 ½"	350 ½"	455 ½"	455 ½"	595 ½"	685 ½"
P2 Sensor	mm Ø	700 ½"	955 ½"	920 ½"	935 ½"	1095 ½"	1165 ½"	1160 ½"
AS1 PHE fitting	mm Ø	275 1"¼	595 1"¼	635 1"¼	680 1"¼	930 1"¼	1005 1"¼	895 1"¼
AS2 PHE fitting	mm Ø	1075 1"¼	1395 1"¼	1435 1"¼	1480 1"¼	1730 1"¼	1805 1"¼	1695 1"¼
T Thermometer	mm Ø	1075 ½"	1395 ½"	1435 ½"	1480 ½"	1730 ½"	1805 ½"	1695 ½"
A1 Anode	mm Ø	325 M8	325 M8	350 M8	405 M8	405 M8	555 1"¼	—
A2 Anode	mm Ø	1320 1"¼	1640 1"¼	1720 1"¼	1779 1"¼	2029 1"¼	2185 1"¼	2165 1"¼
A3 Anode	mm Ø	—	—	—	1779 1"¼	2029 1"¼	2185 1"¼	2165 1"¼
A4 Anode	mm Ø	—	—	—	—	—	—	740 1"¼
S1 Spiral coil primary outlet	mm Ø	990 1"¼	1235 1"¼	1285 1"¼	1315 1"¼	1620 1"¼	1655 2"	1650 2"
S2 Spiral coil primary inlet	mm Ø	255 1"¼	255 1"¼	295 1"¼	345 1"¼	345 1"¼	465 2"	595 2"
EP Primary inlet (PHE)	mm Ø	1075 1"¼M	1395 1"¼M	1435 1"¼M	1480 1"¼M	1730 1"¼M	1805 1"¼M	1695 1"¼M
UP Primary outlet (PHE)	mm Ø	695 1"¼M	1015 1"¼M	1055 1"¼M	1100 1"¼M	1350 1"¼M	1425 1"¼M	1315 1"¼M
FL Inspection opening	mm Ø	325 120x184	325 120x184	350 120x184	405 120x184	405 120x184	555 120x184	685 220x300
PERFORMANCE								
Spiral coil surface area	m²	3,0	4,2	6,0	7,5	10,0	12,0	13,0
Spiral coil output (Primary 50/45°C - Secondary 10/45°C)	kW	21	29	42	52	70	84	91
DHW continuous flow 10/45°C	l/h	516	720	1029	1286	1714	2057	2229
WEIGHT								
Empty weight	kg	160	175	228	314	382	439	509

NOTE: All the measurements of the hydraulic connections are considered "from the ground" - All the threads are female GAS type, unless otherwise specified. Tanks higher than 2200mm are packaged horizontally.

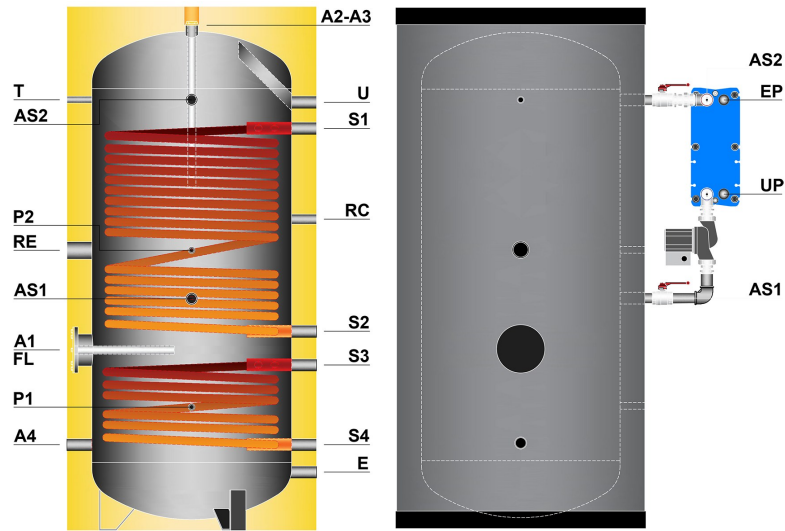

BKPN2I-V GENERAL CHARACTERISTICS

	Capacity	300	500	800	1000	1500	2000
DIMENSIONS							
Diameter without insulation	mm	500	650	800	800	1000	1200
Diameter with insulation	mm	610	760	1000	1000	1200	1400
Maximum height	mm	1640	1720	1854	2104	2265	2245
Overturning height with without insulation	mm	1760	1890	2110 1840	2330 2080	2570 2280	2650 2280
CONNENCTIONS							
	H from ground Ø						
E Cold water inlet	mm Ø	150 1"	185 1"	235 1"¼	235 1"¼	315 2"	445 2"
U Hot water outlet	mm Ø	1395 1"	1515 1"	1470 1"¼	1720 1"¼	1795 2"	1815 2"
RC Recirculation	mm Ø	1050 1"	1095 1"	1150 1"	1250 1"	1420 1"½	1450 1"½
R Immersion electric heater	mm Ø	890 2"	970 2"	1045 2"	1125 2"	1305 2"	1380 2"
P1 Sensor	mm Ø	385 ½"	440 ½"	455 ½"	495 ½"	595 ½"	725 ½"
P2 Sensor	mm Ø	890 ½"	970 ½"	1045 ½"	1125 ½"	1305 ½"	1380 ½"
AS1 PHE fitting	mm Ø	595 1"¼	635 1"¼	680 1"¼	930 1"¼	1005 1"¼	895 1"¼
AS2 PHE fitting	mm Ø	1395 1"¼	1435 1"¼	1480 1"¼	1730 1"¼	1805 1"¼	1695 1"¼
T Thermometer	mm Ø	1395 ½"	1435 ½"	1480 ½"	1730 ½"	1805 ½"	1695 ½"
A1 Anode	mm Ø	665 M8	685 M8	680 M8	725 M8	580 1"¼	—
A2 Anode	mm Ø	1640 1"¼	1720 1"¼	1779 1"¼	2029 1"¼	2185 1"¼	2165 1"¼
A3 Anode	mm Ø	—	—	1779 1"¼	2029 1"¼	2185 1"¼	2165 1"¼
A4 Anode	mm Ø	—	—	—	—	—	555 1"¼
S1 Upper Spiral coil primary outlet	mm Ø	1305 1"¼	1405 1"¼	1365 1"¼	1615 1"¼	1655 1"½	1680 1"½
S2 Upper Spiral coil primary inlet	mm Ø	710 1"¼	760 1"¼	760 1"¼	800 1"¼	955 1"½	1080 1"½
S3 Lower Spiral coil primary outlet	mm Ø	620 1"¼	605 1"¼	625 1"¼	665 1"¼	805 1"½	930 1"½
S4 Lower Spiral coil primary inlet	mm Ø	250 1"¼	295 1"¼	345 1"¼	345 1"¼	435 1"½	585 1"½
EP Primary inlet (PHE)	mm Ø	1395 1"¼M	1435 1"¼M	1480 1"¼M	1730 1"¼M	1805 1"¼M	1695 1"¼M
UP Primary outlet (PHE)	mm Ø	1015 1"¼M	1055 1"¼M	1100 1"¼M	1350 1"¼M	1425 1"¼M	1315 1"¼M
FL Inspection opening	mm Ø	665 120x184	685 120x184	680 120x184	725 120x184	580 120x184	1005 220x300
PERFORMANCE							
Lower Spiral coil surface area	m²	1,7	1,8	2,0	3,0	4,5	5,0
Lower Spiral coil output (Primary 75/65°C - Secondary 10/45°C)	kW	50	53	59	89	133	149
DHW continuous flow 10/45°C	l/h	1239	1311	1457	2186	3279	3649
Upper Spiral coil surface area	m²	2,5	4,1	5,0	6,0	7,0	8,0
Upper Spiral coil output (Primary 50/45°C - Secondary 10/45°C)	kW	17	29	35	42	49	56
DHW continuous flow 10/45°C	l/h	429	703	857	1029	1200	1371
WEIGHT							
Empty weight	kg	180	230	301	357	429	514

NOTE: All the measurements of the hydraulic connections are considered "from the ground" - All the threads are female GAS type, unless otherwise specified. Tanks higher than 2200mm are packaged horizontally.

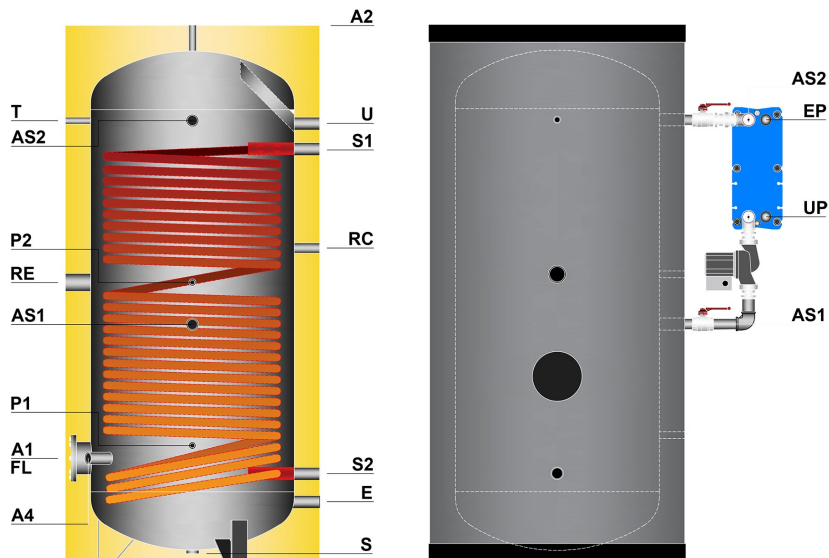

BKPN1-X GENERAL CHARACTERISTICS

	Capacity	200	300	500	800	1000	1500	2000
DIMENSIONS								
Diameter without insulation	mm	500	500	650	800	800	1000	1200
Diameter with insulation	mm	610	610	760	1000	1000	1200	1400
Maximum height	mm	1320	1640	1715	1854	2104	2205	2245
Overturning height with without insulation	mm	1460	1760	1890	2110 1840	2340 2090	2520 2270	2650 2330
CONNECTIONS								
		H from ground Ø						
E Cold water inlet	mm Ø	150 1"	150 1"	185 1"	235 1"¼	235 1"¼	315 2"	445 2"
U Hot water outlet	mm Ø	1070 1"	1395 1"	1515 1"	1470 1"¼	1720 1"¼	1795 2"	1815 2"
RC Recirculation	mm Ø	770 1"	1050 1"	1095 1"	1050 1"	1230 1"	1300 1"½	1300 1"½
R Immersion electric heater	mm Ø	700 2"	955 2"	920 2"	935 2"	1095 2"	1165 2"	1160 2"
P1 Sensor	mm Ø	360 ½"	345 ½"	350 ½"	455 ½"	455 ½"	595 ½"	685 ½"
P2 Sensor	mm Ø	700 ½"	955 ½"	920 ½"	935 ½"	1095 ½"	1165 ½"	1160 ½"
AS1 PHE fitting	mm Ø	275 1"¼	595 1"¼	635 1"¼	680 1"¼	930 1"¼	1005 1"¼	895 1"¼
AS2 PHE fitting	mm Ø	1075 1"¼	1395 1"¼	1435 1"¼	1480 1"¼	1730 1"¼	1805 1"¼	1695 1"¼
T Thermometer	mm Ø	1075 ½"	1395 ½"	1435 ½"	1480 ½"	1730 ½"	1805 ½"	1695 ½"
A1 Anode	mm Ø	—	—	—	—	—	555 ½"	—
A2 Anode	mm Ø	1320 ½"	1640 ½"	1715 ½"	1854 ½"	2104 ½"	2205 ½"	2245 ½"
A4 Anode	mm Ø	—	—	—	—	—	—	740 ½"
S1 Spiral coil primary outlet	mm Ø	990 1"¼	1235 1"¼	1285 1"¼	1315 1"¼	1620 1"¼	1655 2"	1650 2"
S2 Spiral coil primary inlet	mm Ø	255 1"¼	255 1"¼	295 1"¼	345 1"¼	345 1"¼	465 2"	595 2"
S Drain	mm Ø	—	—	—	—	—	110 1"¼	90 1"¼
EP Primary inlet (PHE)	mm Ø	1075 1"¼M	1395 1"¼M	1435 1"¼M	1480 1"¼M	1730 1"¼M	1805 1"¼M	1695 1"¼M
UP Primary outlet (PHE)	mm Ø	695 1"¼M	1015 1"¼M	1055 1"¼M	1100 1"¼M	1350 1"¼M	1425 1"¼M	1315 1"¼M
FL Inspection opening	mm Ø	325 120x184	325 120x184	350 120x184	405 120x184	405 120x184	555 120x184	685 220x300
PERFORMANCE								
Spiral coil surface area	m²	3,0	4,2	6,0	7,5	10,0	12,0	13,0
Spiral coil output (Primary 50/45°C - Secondary 10/45°C)	kW	21	29	42	52	70	84	91
DHW continuous flow 10/45°C	l/h	516	720	1029	1286	1714	2057	2229
WEIGHT								
Empty weight	kg	154	163	215	306	360	427	500

NOTE: All the measurements of the hydraulic connections are considered "from the ground" - All the threads are female GAS type, unless otherwise specified. Tanks higher than 2200mm are packaged horizontally.

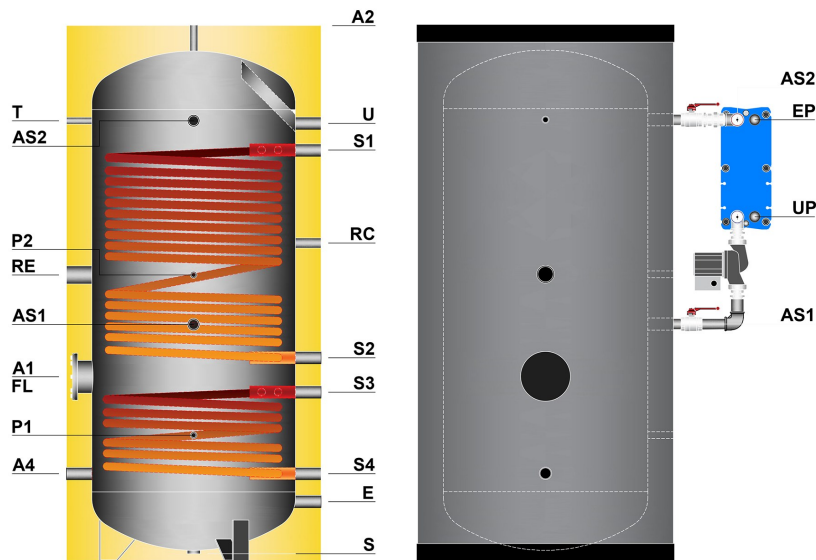

BKPN12-X GENERAL CHARACTERISTICS

		Capacity	300	500	800	1000	1500	2000
DIMENSIONS								
Diameter without insulation	mm	500	650	800	800	1000	1200	
Diameter with insulation	mm	610	760	1000	1000	1200	1400	
Maximum height	mm	1640	1715	1854	2104	2205	2245	
Overturning height with without insulation	mm	1760	1890	2110 1840	2340 2090	2520 2270	2650 2330	
CONNECTIONS								
		H from ground Ø						
E Cold water inlet	mm Ø	150 1"	185 1"	235 1"¼	235 1"¼	315 2"	445 2"	
U Hot water outlet	mm Ø	1395 1"	1515 1"	1470 1"¼	1720 1"¼	1795 2"	1815 2"	
RC Recirculation	mm Ø	1050 1"	1095 1"	1150 1"	1250 1"	1420 1"½	1450 1"½	
R Immersion electric heater	mm Ø	890 2"	970 2"	1045 2"	1125 2"	1305 2"	1380 2"	
P1 Sensor	mm Ø	385 ½"	440 ½"	455 ½"	495 ½"	595 ½"	725 ½"	
P2 Sensor	mm Ø	890 ½"	970 ½"	1045 ½"	1125 ½"	1305 ½"	1380 ½"	
AS1 PHE fitting	mm Ø	595 1"¼	635 1"¼	680 1"¼	930 1"¼	1005 1"¼	895 1"¼	
AS2 PHE fitting	mm Ø	1395 1"¼	1435 1"¼	1480 1"¼	1730 1"¼	1805 1"¼	1695 1"¼	
T Thermometer	mm Ø	1395 ½"	1435 ½"	1480 ½"	1730 ½"	1805 ½"	1695 ½"	
A1 Anode	mm Ø	—	—	—	—	580 ½"	—	
A2 Anode	mm Ø	1640 ½"	1715 ½"	1854 ½"	2104 ½"	2205 ½"	2245 ½"	
A4 Anode	mm Ø	—	—	—	—	—	555 ½"	
S1 Upper Spiral coil primary outlet	mm Ø	1305 1"¼	1405 1"¼	1365 1"¼	1615 1"¼	1655 1"½	1680 1"½	
S2 Upper Spiral coil primary inlet	mm Ø	710 1"¼	760 1"¼	760 1"¼	800 1"¼	955 1"½	1080 1"½	
S3 Lower Spiral coil primary outlet	mm Ø	620 1"¼	605 1"¼	625 1"¼	665 1"¼	805 1"½	930 1"½	
S4 Lower Spiral coil primary inlet	mm Ø	250 1"¼	295 1"¼	345 1"¼	345 1"¼	435 1"½	585 1"½	
EP Primary inlet (PHE)	mm Ø	1395 1"¼M	1435 1"¼M	1480 1"¼M	1730 1"¼M	1805 1"¼M	1695 1"¼M	
UP Primary outlet (PHE)	mm Ø	1015 1"¼M	1055 1"¼M	1100 1"¼M	1350 1"¼M	1425 1"¼M	1315 1"¼M	
FL Inspection opening	mm Ø	665 120x184	685 120x184	680 120x184	725 120x184	580 120x184	1005 220x300	
PERFORMANCE								
Lower Spiral coil surface area	m²	1,7	1,8	2,0	3,0	4,5	5,0	
Lower Spiral coil output (Primary 75/65°C - Secondary 10/45°C)	kW	50	53	59	89	133	149	
DHW continuous flow 10/45°C	l/h	1239	1311	1457	2186	3279	3649	
Upper Spiral coil surface area	m²	2,5	4,1	5,0	6,0	7,0	8,0	
Upper Spiral coil output (Primary 50/45°C - Secondary 10/45°C)	kW	17	29	35	42	49	56	
DHW continuous flow 10/45°C	l/h	429	703	857	1029	1200	1371	
WEIGHT								
Empty weight	kg	174	225	293	350	418	498	

NOTE: All the measurements of the hydraulic connections are considered "from the ground" - All the threads are female GAS type, unless otherwise specified. Tanks higher than 2200mm are packaged horizontally.

BKPN1-V | BKPN1-X - SINGLE COIL OUTPUT

Primary (60-50)°C | Secondary (10-45)°C

Tank capacity	HP coil surface area	Max. output	Primary flow	SECONDARY (DHW)		
				Continuous flow	Output first 10'	Output first 60'
<i>Litres</i>	<i>m²</i>	<i>kW</i>	<i>Litres/Hour</i>	<i>Litres/Hour</i>	<i>Litres</i>	<i>Litres</i>
200	3,0	48	4128	1180	397	1380
300	4,2	67	5775	1650	575	1950
500	6,0	96	8256	2357	893	2857
800	7,5	120	10313	2946	1291	3746
1000	10,0	160	13750	3929	1655	4929
1500	12,0	192	16500	4714	2286	6214
2000	13,0	208	17875	5107	2851	7107

Primary (55-45)°C | Secondary (10-45)°C

Tank capacity	HP coil surface area	Max. output	Primary flow	SECONDARY (DHW)		
				Continuous flow	Output first 10'	Output first 60'
<i>Litres</i>	<i>m²</i>	<i>kW</i>	<i>Litres/Hour</i>	<i>Litres/Hour</i>	<i>Litres</i>	<i>Litres</i>
200	3,0	31	2666	762	327	962
300	4,2	44	3780	1080	480	1380
500	6,0	63	5400	1543	757	2043
800	7,5	78	6750	1929	1121	2729
1000	10,0	105	9000	2571	1429	3571
1500	12,0	126	10800	3086	2014	4586
2000	13,0	136	11700	3343	2557	5343

Primary (50-45)°C | Secondary (10-45)°C

Tank capacity	HP coil surface area	Max. output	Primary flow	SECONDARY (DHW)		
				Continuous flow	Output first 10'	Output first 60'
<i>Litres</i>	<i>m²</i>	<i>kW</i>	<i>Litres/Hour</i>	<i>Litres/Hour</i>	<i>Litres</i>	<i>Litres</i>
200	3,0	21	3612	516	286	716
300	4,2	29	5040	720	420	1020
500	6,0	42	7200	1029	671	1529
800	7,5	52	9000	1286	1014	2086
1000	10,0	70	12000	1714	1286	2714
1500	12,0	84	14400	2057	1843	3557
2000	13,0	91	15600	2229	2371	4229

DHW CALORIFIER WITH BUILT-IN OVERSIZED SPIRAL COILS FOR HP PRIMARY AND EXTERNAL GASKETED PHE KIT

BKPN2-V | BKPN2-X - UPPER COIL OUTPUT (HP)

Primary (65-50)°C | Secondary (10-45)°C

Tank capacity	HP coil surface area	Max. output	Primary flow	SECONDARY (DHW)		
				Continuous flow	Output first 10'	Output first 60'
<i>Litres</i>	<i>m²</i>	<i>kW</i>	<i>Litres/Hour</i>	<i>Litres/Hour</i>	<i>Litres</i>	<i>Litres</i>
300	2,5	44	2500	1071	479	1371
500	4,1	72	4100	1757	793	2257
800	5,0	87	5000	2143	1157	2943
1000	6,0	105	6000	2571	1429	3571
1500	7,0	122	7000	3000	2000	4500
2000	8,0	140	8000	3429	2571	5429

Primary (55-45)°C | Secondary (10-45)°C

Tank capacity	HP coil surface area	Max. output	Primary flow	SECONDARY (DHW)		
				Continuous flow	Output first 10'	Output first 60'
<i>Litres</i>	<i>m²</i>	<i>kW</i>	<i>Litres/Hour</i>	<i>Litres/Hour</i>	<i>Litres</i>	<i>Litres</i>
300	2,5	26	2250	643	407	943
500	4,1	43	3690	1054	676	1554
800	5,0	52	4500	1286	1014	2086
1000	6,0	63	5400	1543	1257	2543
1500	7,0	73	6300	1800	1800	3300
2000	8,0	84	7200	2057	2343	4057

Primary (50-45)°C | Secondary (10-45)°C

Tank capacity	HP coil surface area	Max. output	Primary flow	SECONDARY (DHW)		
				Continuous flow	Output first 10'	Output first 60'
<i>Litres</i>	<i>m²</i>	<i>kW</i>	<i>Litres/Hour</i>	<i>Litres/Hour</i>	<i>Litres</i>	<i>Litres</i>
300	2,5	17	3000	429	371	729
500	4,1	29	4920	703	617	1203
800	5,0	35	6000	857	943	1657
1000	6,0	42	7200	1029	1171	2029
1500	7,0	49	8400	1200	1700	2700
2000	8,0	56	9600	1371	2229	3371

BKPN2-V | BKPN2-X - LOWER COIL OUTPUT (Additional heating source)

Primary (75-65)°C | Secondary (10-45)°C

Tank capacity	Lower coil surface area	Max. output	Primary flow	SECONDARY (DHW)
				Continuous flow
<i>Litres</i>	<i>m²</i>	<i>kW</i>	<i>Litres/Hour</i>	<i>Litres/Hour</i>
300	1,7	50	4335	1239
500	1,8	53	4590	1311
800	2,0	59	5100	1457
1000	3,0	89	7650	2186
1500	4,5	133	11475	3279
2000	5,0	149	12771	3649

Primary (70-60)°C | Secondary (10-45)°C

Tank capacity	Lower coil surface area	Max. output	Primary flow	SECONDARY (DHW)
				Continuous flow
<i>Litres</i>	<i>m²</i>	<i>kW</i>	<i>Litres/Hour</i>	<i>Litres/Hour</i>
300	1,7	41	3506	1002
500	1,8	43	3713	1061
800	2,0	48	4175	1179
1000	3,0	72	6188	1768
1500	4,5	108	9281	2652
2000	5,0	120	10313	2946

Primary (60-50)°C | Secondary (10-45)°C

Tank capacity	Lower coil surface area	Max. output	Primary flow	SECONDARY (DHW)
				Continuous flow
<i>Litres</i>	<i>m²</i>	<i>kW</i>	<i>Litres/Hour</i>	<i>Litres/Hour</i>
300	1,7	30	1700	729
500	1,8	31	1800	771
800	2,0	35	2000	857
1000	3,0	52	3000	1286
1500	4,5	78	4500	1929
2000	5,0	87	5010	2147

PERFORMANCE AND MATCHING TABLE FOR PK43 GASKETED PLATE HEAT EXCHANGER

Primary (80-60)°C | Secondary (12-48)°C | Primary pressure drop: 30 kPa | Secondary pressure drop: 20 kPa

Capacity <i>L</i>	PK43 Plates No.	Power <i>kW</i>	Primary flow <i>L/h</i>	Continuous production <i>L/h</i>	Production first 10' <i>L</i>	Production first 60' <i>L</i>	Recovery time <i>minutes</i>	NUMBER OF BATHROOMS / SHOWERS			
								Apartments	Hotels	Seasonal hotels	Sport facilities
200	9	50	2150	1194	399	1394	10	17	12	9	7
	17	100	4300	2389	598	2589	5	32	22	16	13
	25	145	6235	3464	777	3664	3	46	31	23	18
	35	200	8600	4778	996	4978	3	62	41	31	25
	43	245	10535	5853	1175	6053	2	76	50	38	30
	51	275	11825	6569	1295	6769	2	85	56	42	34
	61	320	13760	7644	1474	7844	2	98	65	49	39
300	9	50	2150	1194	499	1494	15	20	13	10	8
	17	100	4300	2389	698	2689	8	35	24	18	14
	25	145	6235	3464	877	3764	5	50	33	25	20
	35	200	8600	4778	1096	5078	4	67	45	33	27
	43	245	10535	5853	1275	6153	3	81	54	40	32
	51	275	11825	6569	1395	6869	3	90	60	45	36
	61	320	13760	7644	1574	7944	2	105	70	52	42
500	9	50	2150	1194	699	1694	25	24	16	12	9
	17	100	4300	2389	898	2889	13	40	27	20	16
	25	145	6235	3464	1077	3964	9	55	37	28	22
	35	200	8600	4778	1296	5278	6	73	49	37	29
	43	245	10535	5853	1475	6353	5	88	59	44	35
	51	275	11825	6569	1595	7069	5	98	65	49	39
	61	320	13760	7644	1774	8144	4	113	75	57	45
800	9	50	2150	1194	999	1994	40	29	20	15	12
	17	100	4300	2389	1198	3189	20	47	31	23	19
	25	145	6235	3464	1377	4264	14	63	42	31	25
	35	200	8600	4778	1596	5578	10	82	55	41	33
	43	250	10750	5972	1795	6772	8	100	66	50	40
	51	275	11825	6569	1895	7369	7	108	72	54	43
	61	320	13760	7644	2074	8444	6	124	83	62	50
1000	9	50	2150	1194	1199	2194	50	34	23	17	14
	17	100	4300	2389	1398	3389	25	53	35	26	21
	25	145	6235	3464	1577	4464	17	70	46	35	28
	35	200	8600	4778	1796	5778	13	90	60	45	36
	43	245	10535	5853	1975	6853	10	107	71	54	43
	51	275	11825	6569	2095	7569	9	118	79	59	47
	61	320	13760	7644	2274	8644	8	135	90	68	54
1500	9	50	2150	1194	1699	2694	75	45	30	22	18
	17	100	4300	2389	1898	3889	38	65	43	32	26
	25	145	6235	3464	2077	4964	26	83	55	41	33
	35	200	8600	4778	2296	6278	19	105	70	52	42
	43	245	10535	5853	2475	7353	15	123	82	61	49
	51	275	11825	6569	2595	8069	14	134	90	67	54
	61	320	13760	7644	2774	9144	12	152	102	76	61
2000	9	50	2150	1194	2199	3194	100	57	38	29	23
	17	100	4300	2389	2398	4389	50	78	52	39	31
	25	145	6235	3464	2577	5464	35	98	65	49	39
	35	200	8600	4778	2796	6778	25	121	81	61	48
	43	245	10535	5853	2975	7853	21	140	93	70	56
	51	275	11825	6569	3095	8569	18	153	102	77	61
	61	320	13760	7644	3274	9644	16	172	115	86	69

DHW CALORIFIER WITH BUILT-IN OVERSIZED SPIRAL COILS FOR HP PRIMARY AND EXTERNAL GASKETED PHE KIT

PERFORMANCE AND MATCHING TABLE FOR PK43 GASKETED PLATE HEAT EXCHANGER

Primary (65-50)°C | Secondary(12-48)°C | Primary pressure drop: 30 kPa | Secondary pressure drop: 20 kPa

Capacity L	PK43 Plates No.	Power kW	Primary flow L/h	Continuos production L/h	Production first 10' L	Production first 60' L	Recovery time minutes	NUMBER OF BATHROOMS / SHOWERS			
								Apartments	Hotels	Seasonal hotels	Sport facilities
200	9	30	1720	717	319	917	17	11	8	6	5
	17	65	3727	1553	459	1753	8	22	15	11	9
	25	95	5447	2269	578	2469	5	31	21	15	12
	35	130	7453	3106	718	3306	4	41	28	21	17
	43	160	9173	3822	837	4022	3	50	34	25	20
	51	185	10607	4419	937	4619	3	58	38	29	23
	61	225	12900	5375	1096	5575	2	70	46	35	28
300	9	30	1720	717	419	1017	25	13	9	7	5
	17	65	3727	1553	559	1853	12	24	16	12	10
	25	95	5447	2269	678	2569	8	34	23	17	14
	35	130	7453	3106	818	3406	6	45	30	22	18
	43	160	9173	3822	937	4122	5	54	36	27	22
	51	185	10607	4419	1037	4719	4	62	41	31	25
	61	225	12900	5375	1196	5675	3	75	50	37	30
500	9	30	1720	717	619	1217	42	17	11	8	7
	17	65	3727	1553	759	2053	19	29	19	14	11
	25	95	5447	2269	878	2769	13	38	26	19	15
	35	130	7453	3106	1018	3606	10	50	33	25	20
	43	160	9173	3822	1137	4322	8	60	40	30	24
	51	185	10607	4419	1237	4919	7	68	46	34	27
	61	225	12900	5375	1396	5875	6	82	54	41	33
800	9	30	1720	717	919	1517	67	22	15	11	9
	17	65	3727	1553	1059	2353	31	35	23	17	14
	25	95	5447	2269	1178	3069	21	45	30	23	18
	35	130	7453	3106	1318	3906	15	57	38	29	23
	43	160	9173	3822	1437	4622	13	68	45	34	27
	51	185	10607	4419	1537	5219	11	77	51	38	31
	61	225	12900	5375	1696	6175	9	91	61	45	36
1000	9	30	1720	717	1119	1717	84	27	18	13	11
	17	65	3727	1553	1259	2553	39	40	27	20	16
	25	95	5447	2269	1378	3269	26	51	34	26	20
	35	130	7453	3106	1518	4106	19	64	43	32	26
	43	160	9173	3822	1637	4822	16	75	50	38	30
	51	185	10607	4419	1737	5419	14	85	56	42	34
	61	225	12900	5375	1896	6375	11	100	66	50	40
1500	9	30	1720	717	1619	2217	126	37	25	18	15
	17	65	3727	1553	1759	3053	58	51	34	25	20
	25	95	5447	2269	1878	3769	40	63	42	31	25
	35	130	7453	3106	2018	4606	29	77	51	38	31
	43	160	9173	3822	2137	5322	24	89	59	44	35
	51	185	10607	4419	2237	5919	20	99	66	49	39
	61	225	12900	5375	2396	6875	17	115	76	57	46
2000	9	30	1720	717	2119	2717	167	49	32	24	19
	17	65	3727	1553	2259	3553	77	63	42	32	25
	25	95	5447	2269	2378	4269	53	76	51	38	30
	35	130	7453	3106	2518	5106	39	91	61	46	36
	45	160	9173	3822	2637	5822	31	104	69	52	42
	51	185	10607	4419	2737	6419	27	115	76	57	46
	61	225	12900	5375	2896	7375	22	132	88	66	53

PERFORMANCE AND MATCHING TABLE FOR PK43 GASKETED PLATE HEAT EXCHANGER

Primary (55-50)°C | Secondary (12-48)°C | Primary pressure drop: 40 kPa | Secondary pressure drop: 20 kPa

Capacity <i>L</i>	PK43 Plates No.	Power <i>kW</i>	Primary flow <i>L/h</i>	Continuos production <i>L/h</i>	Production first 10 <i>L</i>	Production first 60 <i>L</i>	Recovery time <i>minutes</i>	NUMBER OF BATHROOMS / SHOWERS			
								Apartments	Hotels	Seasonal hotels	Sport facilities
200	9	13	2236	311	252	511	39	6	4	3	3
	17	25	4300	597	300	797	20	10	7	5	4
	25	38	6536	908	351	1108	13	14	9	7	6
	35	49	8428	1171	395	1371	10	17	11	9	7
	43	60	10320	1433	439	1633	8	20	14	10	8
	51	68	11696	1624	471	1824	7	23	15	11	9
	61	80	13760	1911	519	2111	6	26	18	13	11
300	9	13	2236	311	352	611	58	8	5	4	3
	17	25	4300	597	400	897	30	12	8	6	5
	25	38	6536	908	451	1208	20	16	11	8	6
	35	49	8428	1171	495	1471	15	19	13	10	8
	43	60	10320	1433	539	1733	13	23	15	11	9
	51	68	11696	1624	571	1924	11	25	17	13	10
	61	80	13760	1911	619	2211	9	29	19	15	12
500	9	13	2236	311	552	811	97	11	8	6	5
	17	25	4300	597	600	1097	50	15	10	8	6
	25	38	6536	908	651	1408	33	20	13	10	8
	35	49	8428	1171	695	1671	26	23	15	12	9
	43	60	10320	1433	739	1933	21	27	18	13	11
	51	68	11696	1624	771	2124	18	30	20	15	12
	61	80	13760	1911	819	2411	16	33	22	17	13
800	9	13	2236	311	852	1111	155	16	11	8	7
	17	25	4300	597	900	1397	80	21	14	10	8
	25	38	6536	908	951	1708	53	25	17	13	10
	35	49	8428	1171	995	1971	41	29	19	14	12
	43	60	10320	1433	1039	2233	33	33	22	16	13
	51	68	11696	1624	1071	2424	30	36	24	18	14
	61	80	13760	1911	1119	2711	25	40	27	20	16
1000	9	13	2236	311	1052	1311	193	20	14	10	8
	17	25	4300	597	1100	1597	100	25	17	12	10
	25	38	6536	908	1151	1908	66	30	20	15	12
	35	49	8428	1171	1195	2171	51	34	23	17	14
	43	60	10320	1433	1239	2433	42	38	25	19	15
	51	68	11696	1624	1271	2624	37	41	27	21	16
	61	80	13760	1911	1319	2911	31	45	30	23	18
1500	9	13	2236	311	1552	1811	290	30	20	15	12
	17	25	4300	597	1600	2097	151	35	23	17	14
	25	38	6536	908	1651	2408	99	40	27	20	16
	35	49	8428	1171	1695	2671	77	45	30	22	18
	43	60	10320	1433	1739	2933	63	49	33	24	20
	51	68	11696	1624	1771	3124	55	52	35	26	21
	61	80	13760	1911	1819	3411	47	57	38	28	23
2000	9	13	2236	311	2052	2311	386	41	28	21	17
	17	25	4300	597	2100	2597	201	46	31	23	19
	25	38	6536	908	2151	2908	132	52	35	26	21
	35	49	8428	1171	2195	3171	103	57	38	28	23
	45	60	10320	1433	2239	3433	84	61	41	31	25
	51	68	11696	1624	2271	3624	74	65	43	32	26
	61	80	13760	1911	2319	3911	63	70	47	35	28

BKPN1-V | BKPN1-X - SINGLE COIL PRESSURE DROP

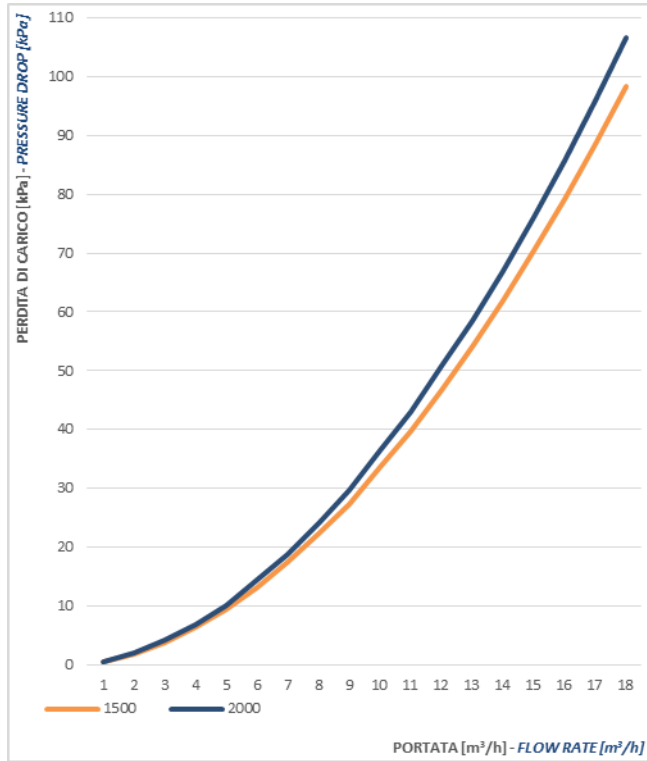
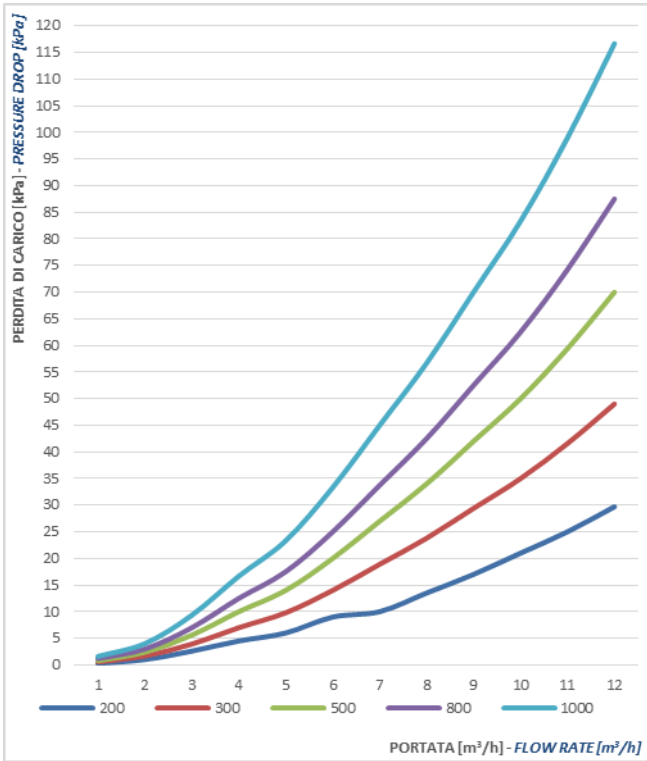

BKPN2-V | BKPN2-X - TWIN COIL PRESSURE DROP

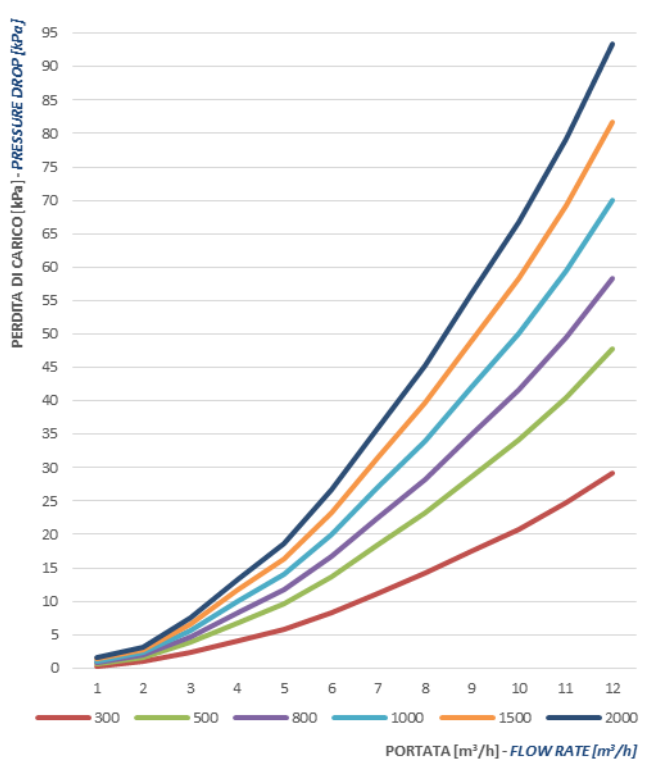

UPPER SPIRAL COIL

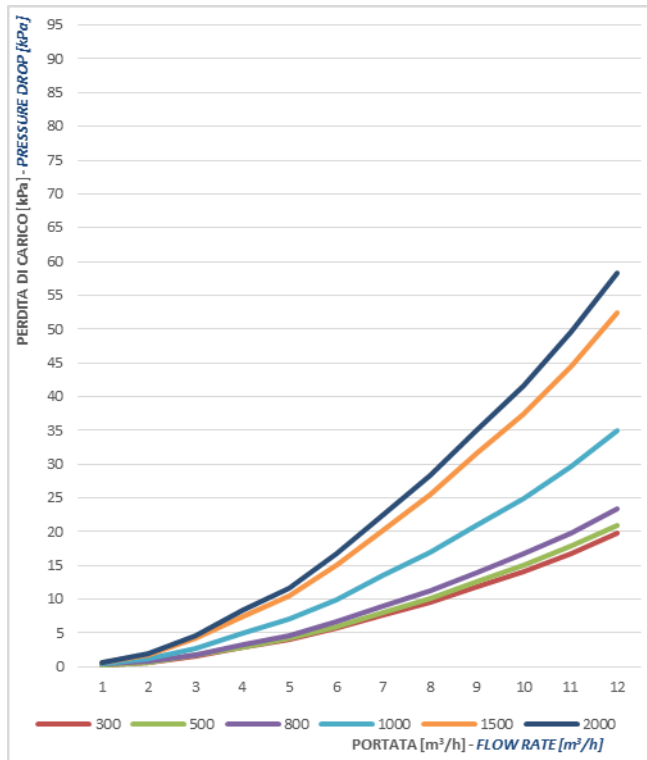

LOWER SPIRAL COIL







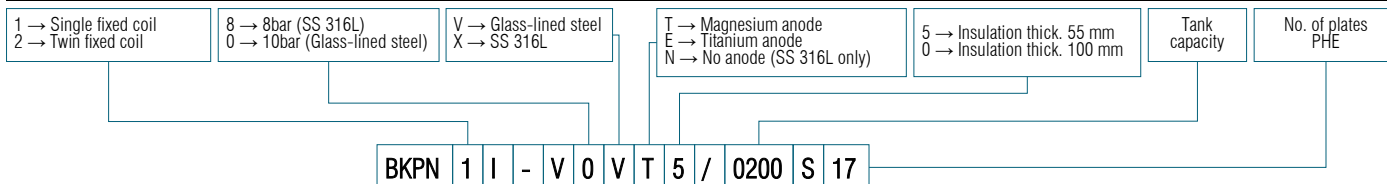

PUMP ENERGY CONSUMPTION

	ENERGY CONSUMPTION 1-SPEED	ENERGY CONSUMPTION 2-SPEED	ENERGY CONSUMPTION 3-SPEED
	W	W	W
PK 43 9 to 25 plates	50	74	99
PK 43 26 to 35 plates	120	175	200
PK 43 36 to 61 plates	295	315	335

HOW TO ORDER



ACCESSORIES & SPARE PARTS

ITEM	PART.NO		
THERMOMETER Ø65 mm L=50 mm (0÷120)°C	TERMOMETRO-D65_S		THERMOMETER
PROBE SOCKET Ø½" L=50 mm Ø _{int} 10 mm	POZZETTO_S		PROBE SOCKET
THERMOSTAT Ø½" (0÷90)°C	TERMOSTATO		THERMOSTAT
MANHOLE EPDM GASKET 200÷1500 L	GUGOM175X122ST		
MANHOLE EPDM GASKET 2000 L	GUGOMEPM300X220ST		
GLASS ENAMELLED TANKS			
MAGNESIUM ANODE SET BKPN-V 200 L	KIT-ANOD_20		MAGNESIUM ANODE
MAGNESIUM ANODE SET BKPN-V 300 L	KIT-ANOD_21		
MAGNESIUM ANODE SET BKPN-V 500 L	KIT-ANOD_22		
MAGNESIUM ANODE SET BKPN-V 800 L	KIT-ANOD_23		
MAGNESIUM ANODE SET BKPN-V 1000 L	KIT-ANOD_24		
MAGNESIUM ANODE SET BKPN-V 1500 L	KIT-ANOD_25		
MAGNESIUM ANODE SET BKPN-V 2000 L	KIT-ANOD_26		
TITANIUM ANODE for glass-enamelled tanks 200÷500 L	ANODE012X380_P		TITANIUM ANODE
TITANIUM ANODE for glass-enamelled tanks 800÷1000 L	ANODE012X430_P		
TITANIUM ANODE for glass-enamelled tanks 1500÷2000 L	ANODE012X430X2_P		
GLASS-LINED BLIND FLANGE Ø180 mm W/ ANODE HOLE BKPN-V 200÷1500 L	PIASTRAN180-V-F		BLIND FLANGE
GLASS-LINED BLIND FLANGE Ø300 mm BKPN-V 2000 L	PIASTRAN300-V		MANHOLE EPDM GASKET
STAINLESS STEEL 316L TANKS			
TITANIUM ANODE for SS 316L tanks 200÷1000 L	ANODE_ARTHX1-150/400		
TITANIUM ANODE for SS 316L tanks 1500-2000 L	ANODE_ARTHX2-150/400		
STAINLESS STEEL 316L BLIND FLANGE Ø180 mm BKPN-X 200÷1500 L	PIASTRAX180		
STAINLESS STEEL 316L BLIND FLANGE Ø300 mm BKPN-X 2000 L	PIASTRAX300-6X		
GASKETED PLATE HEAT EXCHANGER PK 43			
EPDM GASKET	G043-E		GASKETS
REMOVABLE INSULATION SMALL SIZE (PK 43 - 7 to 25 plates)	ISOLPK043_COMP-C		
REMOVABLE INSULATION LARGE SIZE (PK 43 - 26 to 61 plates)	ISOLPK043_COMP-L		PHE THERMAL INSULATION

1-PHASE & 3-PHASE IMMERSION ELECTRIC HEATER - STAINLESS STEEL 316L TUBES
 Threaded plug 1.1/2" with brass adapter 1.1/2" to 2" | Aluminium box IP54 | V220/1-V240/1 or V400/3

Capacity	Capacity/L matching	Length	Volt	Plug type	2-THERMOSTAT Temperature regulation & overheating protection PART NO.
<i>Watt</i>	<i>L</i>	<i>mm</i>	<i>mm</i>	<i>mm</i>	
2000	200 ÷ 2000	310	220/1	SHUKO	RES020-L310-6-M-BT
3000	200 ÷ 2000	350	240/1		RES030-L350-6-M-BT
5000	200 ÷ 2000	375	400/3	Not supplied	RES050-L375-6-T-BT
6000	200 ÷ 2000	435			RES060-L435-6-T-BT
9000	500 ÷ 2000	610			RES090-L610-6-T-BT
10000	500 ÷ 2000	670			RES100-L670-6-T-BT
12000	800 ÷ 2000	730			RES120-L727-6-T-BT
15000	1500 ÷ 5000	870			RES150-L870-6-T-BT



1-PHASE



3-PHASE

PROTECTIVE TREATMENTS FOR CARBON STEEL TANKS

Glass-enamelling.

The glass-enamelling treatment is obtained with the application of one or two layers of enamel with characteristics of resistance to water and steam, which gives the treated product a high level of protection against the corrosion normally caused by the oxygen and the mineral salts dissolved in the water. The complete reliability of this type of treatment derives from its inorganic composition and from the link created between the enamel and the metallic surface.

After baking in an oven at about 850°C according to Bayer's method and DIN 4753.3 the enamel does not absorb water and does not conduct ions, allowing the 99.9% protection of the structure of the product. The remaining 0.01% (due to possible uncovered spots) is eliminated by inserting protective anticorrosive systems into the product such as the sacrificial magnesium anodes or the permanent electronic anodes.

PROTECTIVE TREATMENTS FOR STAINLESS STEEL TANKS.

Pickling and passivation

The calorifiers manufactured with the use of stainless steels are treated with pickling procedures with full immersion and subsequent passivation, where planned.

CATHODIC PROTECTION

The corrosion of a metal structure occurs mainly in areas in which there is the passage of current (oxidation-reduction process) from the structure towards the outside (water or gas) causing a dissolution of the structure itself.

Cathodic protection by means of magnesium anodes.

The application of sacrificial magnesium anodes is a simple and economic method to obtain a cathodic protection.

The sacrificial anode creates a situation similar to an electric battery, where the electrodes are represented by the anode and the metal structure to be protected.

Since the magnesium has a dissolution voltage which is much higher than that of other metals, the corrosion will only affect the anode, which will dissolve slowly, to the advantage of the metal structure to be protected.

Given the importance of the protection of the metal against corrosion, the wear of the anode is systematically controlled and it is immediately replaced if consumed.



Cathodic protection by means of electronic impressed current system.

As an alternative to the galvanic system (coupling of materials with different potentials) there is a protection method which consists in applying an equal and opposite continuous current to the metallic structure to be protected, neutralising the voltages formed inside the tank.

Thanks to the modern techniques there is an innovative electronic system of cathodic protection with continuous impressed current.

The main advantages are:

- active protection by means of impressed currents from the outside;
- excellent flexibility of operation in order to adhere to the changeable internal coating conditions and the mass of water;
- reduction of maintenance costs due to the permanent protection of the system.



INSULATION

Insulating material	Removable	Thickness	Density	Thermal conductivity coefficient at 45°C	Operating temperature	Fire reaction class Euroclass EN13501-1
PLFH High density polyester fibre	✓	100 mm	25 kg/m ³	$\lambda = 0,034 \text{ W/mK}$	Amb. / +99°C	B-s2, d0
Hard polyurethane injected	✗	55 mm	40 ÷ 42 kg/m ³	$\lambda = 0,019 \text{ W/mK}$	-10°C / +99°C	F

PLF – Polyester fibre

- 100% recyclable
- Environmentally compatible
- Lightweight
- Self-supporting
- Fire-retardant
- Rot-proof
- Cannot be attacked by mould, bacteria or rodents
- Hypoallergenic
- Water repellent



The raw materials consist of polyester fibres and heat-bonded co-polyester fibres, coming mainly from the recycling of plastic bottles obtained from urban waste collection. It does not contain substances harmful to humans, may be handled and installed in complete safety, does not release powder, is hypoallergenic and cannot be attacked by microorganisms, mould and insects. PLFH/PLF is a heat insulating product considered environmentally sustainable, even though it is not of natural origin: it is in fact recyclable and the quantity of embodied energy necessary to obtain it is extremely low. The composition of the polyester fibre makes it an insulating material with an extremely low heat dispersion and its characteristics remain unaltered over time as it is not affected by humidity and its compact, flexible and resistant original structure is not modified. Thanks to its characteristics, PLFH/PLF is an insulating material with the highest performance characteristics, which allows the requirements set by the severest technical standards to be satisfied, guaranteeing the maximum environmental compatibility for its entire life cycle.

Hard polyurethane

Thermal and anti-condensation insulation made of rigid closed cell polyurethane foam (PU), free from CFC and HCFC. It is available in various thickness and can be injected directly to the walls of the tank to eliminate the possibility of formation of condensation and guarantee the minimum thermal dispersion, or pre-formed in removable half-shells to conserve the heat accumulated in the tank. The extremely low thermal conductivity coefficient not only allows the limits specified by the ErP reference standard to be complied with, but actually to improve on them: the tanks of the new  range, thanks to the careful study of the thicknesses and of the compounds, obtain the prestigious energy class "A" due to their limited heat dispersion values.

CLADDINGS



PVC

External cladding made of coloured PVC with hinge closing, suitable for installations in locations protected against adverse weather conditions. The standard colours of each product are indicated in their construction characteristics, but different colours can be requested for each model as shown in the following table. In the personalised TLR storage tanks the choice of the alternative colour is free of cost and does not incur any surcharge.

ITEM

ITEM	PART NUMBER
PVC COVER YELLOW RAL1023	COVER-RAL1023
PVC COVER ORANGE RAL2004	COVER-RAL2004
PVC COVER RED RAL3000	COVER-RAL3000
PVC COVER BLUE RAL5015	COVER-RAL5015
PVC COVER WHITE RAL9016	COVER-RAL9016
PVC COVER LIGHT GREY RAL7035	COVER-RAL7035
PVC COVER DARK GREY RAL7024	COVER-RAL7024
PVC COVER BLACK RAL9004	COVER-RAL9004

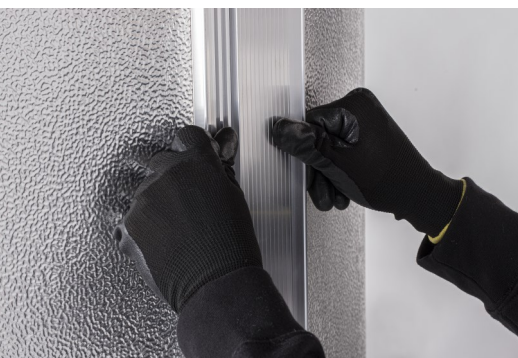

ALUMINIUM

External cladding made of embossed aluminium sheeting suitable also for outdoor installations. The insulations made with this type of cladding consist of panels joined together by means of rivets and extruded aluminium slats with an exclusive design, specifically designed to facilitate assembly even directly at the installation site. The coverings and flange covers made of same material securely anchored to the insulation guarantee the same levels of quality in terms of duration and outside appearance and do not risk being damaged by the wind and adverse weather conditions.

www.pacetti.it



MADE IN ITALY

PACETTI S.r.l.

Via G. Marconi, 240/242

44122 - Ferrara - ITALY

Tel. +39 0532 774066

Fax +39 0532 773835

info@pacetti.it