

dal 1968



SCAMBIATORI - BOLLITORI - SERBATOI



BTVH-Z - BTV-Z



GALVANISED STEEL DHW CALORIFIER EQUIPPED WITH ONE
REMOVABLE TUBE BUNDLE HEAT EXCHANGER
FOR STEAM OR OVERHEATED WATER PRIMARY

Calorifiers made of galvanised steel with one removable tube bundle heat exchanger for production and storage of DHW. Designed for connection to a steam or overheated water primary energy source. The calorifiers of the **BTVH-Z | BTV-Z** range are equipped with removable tube bundle heat exchangers made of Stainless Steel AISI 316L and compliant with PED 2014/68/EU. These batteries are designed to be used when primary media is steam or overheated water and are available in two different options: Primary up to 6 bar (165°DegC) or Primary up to 12 bar (191,7°DegC). They can be either CE marked or not, according to the operation conditions and relevant assessed PED category, if applicable.

The calorifiers of the **BTVH-Z | BTV-Z** range stand out for the wide choice of capacities, from 300 to 5000 L as standard and over upon request. They are available, in the larger sizes, in vertical-low and vertical extra-low versions to allow them to be installed in circumstances where the available height is not sufficient for the standard measurement. The possibility of selecting between various operating pressures - up to 10 bar - and the availability of different external claddings for indoor or outdoor installation, extends their use to all the possible applications. Protection from galvanic currents is provided by the electronic anodes fitted as standard, which both save on costs of checking and replacing conventional magnesium anodes and ensure superior reliability and durability.

CONSTRUCTION

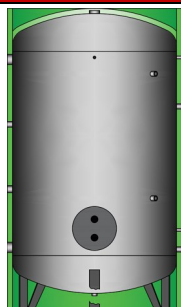

BTVH-Z | BTV-Z

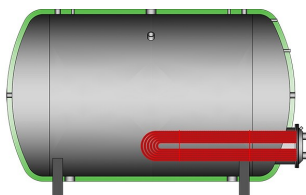

BTVH-OZ | BTV-OZ

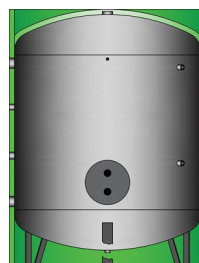

BTVH-RZ | BTV-RZ

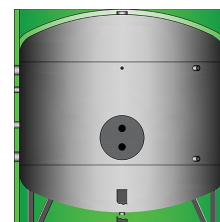

BTV-XZ

TANK MATERIAL	Carbon steel	Carbon steel	Carbon steel	Carbon steel
INTERNAL SURFACE TREATMENT	Hot dip galvanising	Hot dip galvanising	Hot dip galvanising	Hot dip galvanising
EXTERNAL SURFACE TREATMENT	Hot dip galvanising	Hot dip galvanising	Hot dip galvanising	Hot dip galvanising
CAPACITY	300 ÷ 5000 L	300 ÷ 5000 L	1500 ÷ 5000 L	3000 ÷ 5000 L
VERSION	Vertical	Horizontal	Vertical LOW-height	Vertical EXTRA-LOW height
CONNECTIONS	Threaded	Threaded	Threaded	Threaded
REMOVABLE TUBE BUNDLE HEAT EXCHANGER MATERIAL	Stainless steel AISI 316L	Stainless steel AISI 316L	Stainless steel AISI 316L	Stainless steel AISI 316L
PRIMARY CHEST MATERIAL	Dip Galvanized Steel	Dip Galvanized Steel	Dip Galvanized Steel	Dip Galvanized Steel
INSULATION 300-500 L	Hard foam Polyurethane 80 mm injected	Hard foam Polyurethane 50 mm injected	—	—
INSULATION 800 ÷ 2000 L	PLFH 100 mm High density eco-friendly polyester fiber	PLFH 100 mm High density eco-friendly polyester fiber	PLFH 100 mm High density eco-friendly polyester fiber	—
INSULATION 2500 ÷ 5000 L	PLF 50 mm Eco-friendly polyester fiber	PLF 50 mm Eco-friendly polyester fiber	PLF 50 mm Eco-friendly polyester fiber	PLF 50 mm Eco-friendly polyester fiber
CLADDING	<ul style="list-style-type: none"> • PVC Yellow RAL1023 • Aluminium 	<ul style="list-style-type: none"> • PVC Yellow RAL1023 • Aluminium 	<ul style="list-style-type: none"> • PVC Yellow RAL1023 • Aluminium 	<ul style="list-style-type: none"> • PVC Yellow RAL1023 • Aluminium
ANODE	Electronic	Electronic	Electronic	Electronic
ACCESSORIES	Thermometer	Thermometer	Thermometer	Thermometer

Energy efficiency class - Regulation 812/2013 & 814/2013 | European Directive 2009/125/CE

		Capacity - L		300	500	800	1000	1500	2000	2500	3000	4000	5000
BTVH-Z	Energy efficiency class			B	B	C	C	C	C	C	C	C	C
	Standing loss	S	W	64	81	133	143	168	189				
	Storage volume	V	L	294	503	792	915	1482	1986				
BTVH-OZ	Energy efficiency class			C	C	C	C	C	C	C	C	C	C
	Standing loss	S	W	80	103	133	143	168	189				
	Storage volume	V	L	295	487	792	915	1482	1986				
BTVH-RZ	Energy efficiency class									C	C	C	C
	Standing loss	S	W					166	185				
	Storage volume	V	L					1520	1961				

STANDARD WORKING CONDITIONS

		Capacity	300	500	800	1000	1500	2000	2500	3000	4000	5000
Tank working pressure	bar	ATM ÷ 8	ATM ÷ 8	ATM ÷ 8	ATM ÷ 8	ATM ÷ 6	ATM ÷ 6	ATM ÷ 6	ATM ÷ 6	ATM ÷ 6	ATM ÷ 6	ATM ÷ 6
Tank working temperature	°C	AMB ÷ 85	AMB ÷ 85	AMB ÷ 85	AMB ÷ 85	AMB ÷ 85	AMB ÷ 85	AMB ÷ 85	AMB ÷ 85	AMB ÷ 85	AMB ÷ 85	AMB ÷ 85
HEX for primary up to 6 bar	working press.	bar	ATM ÷ 6	ATM ÷ 6	ATM ÷ 6	ATM ÷ 6	ATM ÷ 6	ATM ÷ 6	ATM ÷ 6	ATM ÷ 6	ATM ÷ 6	ATM ÷ 6
	working temp.	°C	AMB ÷ 165	AMB ÷ 165	AMB ÷ 165	AMB ÷ 165	AMB ÷ 165	AMB ÷ 165	AMB ÷ 165	AMB ÷ 165	AMB ÷ 165	AMB ÷ 165
HEX for primary up to 12 bar	working press.	bar	ATM ÷ 12	ATM ÷ 12	ATM ÷ 12	ATM ÷ 12	ATM ÷ 12	ATM ÷ 12	ATM ÷ 12	ATM ÷ 12	ATM ÷ 12	ATM ÷ 12
	working temp.	°C	AMB ÷ 191,7	AMB ÷ 191,7	AMB ÷ 191,7	AMB ÷ 191,7	AMB ÷ 191,7	AMB ÷ 191,7	AMB ÷ 191,7	AMB ÷ 191,7	AMB ÷ 191,7	AMB ÷ 191,7

REGULATORY COMPLIANCE

ErP - Reg. 812/2013 & Reg. 814/2013 | CE
 European Pressure Equipment Directive (PED) 2014/68/UE
 D.M. 174/04 or Reg. (CE) 1935/04 | Compatible with potable water

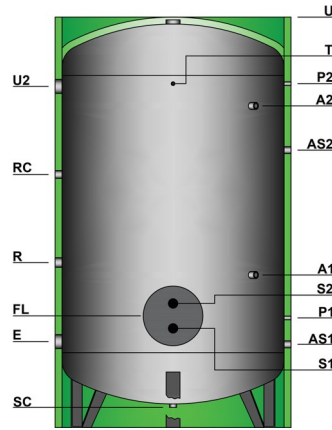

GENERAL CHARACTERISTICS - VERTICAL STANDARD VERSION

	Capacity - L	300	500	800	1000	1500
DIMENSIONS						
Diameter without insulation	mm	550	650	800	800	950
Diameter with insulation	mm	710	810	1000	1000	1150
Overall height	mm	1554	1844	1950	2200	2510
Overturning height with without insulation	mm	1709 —	2014 —	2080 1918	2316 2166	2653 2502

CONNECTIONS

E Cold water supply	mm Ø	369 1 1/2"	384 1 1/2"	420 2"	420 2"	465 2 1/2"
U DHW return	mm Ø	1554 1 1/2"	1844 1 1/2"	1950 2"	2200 2"	2510 2 1/2"
U2 Additional DWH return	mm Ø	—	—	—	—	—
RC Recirculation	mm Ø	1019 1 1/2"	1259 1 1/2"	1370 1 1/2"	1405 1 1/2"	1580 1 1/2"
R Immersion electric heater	mm Ø	789 2"	804 2"	1010 2"	1010 2"	1035 2"
P1 Sensor	mm Ø	489 1/2"	504 1/2"	610 1/2"	608 1/2"	635 1/2"
P2 Sensor	mm Ø	1269 1/2"	1534 1/2"	1550 1/2"	1698 1/2"	2125 1/2"
T Thermometer	mm Ø	1269 1/2"	1534 1/2"	1550 1/2"	1800 1/2"	2125 1/2"
A1 Anode	mm Ø	869 1/2"	884 1/2"	920 1/2"	608 1/2"	945 1/2"
A2 Anode	mm Ø	—	—	—	—	1965 1/2"
AS1 Spare	mm Ø	369 1 1/4"	384 1 1/4"	420 1 1/4"	418 1 1/4"	445 1 1/4"
AS2 Spare	mm Ø	1169 1 1/4"	1184 1 1/4"	1220 1 1/4"	1818 1 1/4"	1845 1 1/4"
FL Heat exchanger manhole	mm Ø	489 220x300	504 220x300	610 300x380	610 300x380	635 300x380
S1 Heat exchanger return	mm Ø	429 1"	444 1"	535 2"	535 2"	560 2"
S2 Heat exchanger supply	mm Ø	549 1"	564 1"	685 2"	685 2"	710 2"
SC Drain	mm Ø	109 1 1/4"	99 1 1/4"	95 1 1/4"	95 1 1/4"	135 1 1/4"

TUBE BUNDLE HEAT EXCHANGERS PERFORMANCES

	m²	0,50	0,75	1,00	1,50	2,00
Heat exchanger heating surface area						
HEX output (Prim. 6 bar - Sec. 15/60°C)	kW	79	119	159	238	317
DHW continuous flow 15/60°C	L/h	1516	2274	3032	4548	6063
HEX output (Prim. 12 bar - Sec. 15/60°C)	kW	96	144	192	288	384
DHW continuous flow 15/60°C	L/h	1837	2755	3674	5511	7347

EMPTY WEIGHTS

Empty weight	kg	85	120	165	185	245
--------------	----	----	-----	-----	-----	-----

DIMENSIONS

	Capacity - L	2000	2500	3000	4000	5000
Diameter without insulation	mm	1100	1200	1250	1400	1600
Diameter with insulation	mm	1300	1300	1350	1500	1700
Overall height	mm	2535	2590	2790	2869	2960
Overturning height with without insulation	mm	2712 2541	2773 2600	2976 2800	3088 2883	3232 2982

CONNECTIONS

E Cold water supply	mm Ø	485 2 1/2"	530 3"	525 3"	559 3"	620 3"
U DHW return	mm Ø	2535 2 1/2"	2590 3"	2790 3"	2869 3"	2960 3"
U2 Additional DWH return	mm Ø	—	—	—	2399 3"	2460 3"
RC Recirculation	mm Ø	1600 1 1/2"	1645 1 1/2"	1730 1 1/2"	1764 1 1/2"	1825 1 1/2"
R Immersion electric heater	mm Ø	1055 2"	1100 2"	1095 2"	1129 2"	1190 2"
P1 Sensor	mm Ø	655 1/2"	700 1/2"	695 1/2"	729 1/2"	790 1/2"
P2 Sensor	mm Ø	2095 1/2"	2190 1/2"	2385 1/2"	2419 1/2"	2480 1/2"
T Thermometer	mm Ø	2095 1/2"	2190 1/2"	2385 1/2"	2419 1/2"	2480 1/2"
A1 Anode	mm Ø	965 1/2"	1010 1/2"	1005 1/2"	1039 1/2"	1100 1/2"
A2 Anode	mm Ø	1935 1/2"	2030 1/2"	2225 1/2"	2259 1/2"	2320 1/2"
AS1 Spare	mm Ø	465 1 1/4"	510 1 1/4"	505 1 1/4"	539 1 1/4"	600 1 1/4"
AS2 Spare	mm Ø	1865 1 1/4"	1910 1 1/4"	1905 1 1/4"	1939 1 1/4"	2000 1 1/4"
FL Heat exchanger manhole	mm Ø	655 300x380	700 300x380	695 300x380	729 350x430	790 350x430
S1 Heat exchanger return	mm Ø	580 2"	625 2"	620 2"	629 2"	690 2"
S2 Heat exchanger supply	mm Ø	730 2"	775 2"	770 2"	829 2"	890 2"
SC Drain	mm Ø	123 1 1/4"	135 1 1/4"	125 1 1/4"	114 1 1/4"	145 1 1/4"

TUBE BUNDLE HEAT EXCHANGERS PERFORMANCES

	m²	2,50	3,00	4,00	5,00	6,00
Heat exchanger heating surface area						
HEX output (Prim. 6 bar - Sec. 15/60°C)	kW	397	476	635	793	952
DHW continuous flow 15/60°C	L/h	7579	9095	12127	15158	18190
HEX output (Prim. 12 bar - Sec. 15/60°C)	kW	481	577	769	961	1153
DHW continuous flow 15/60°C	L/h	9184	11021	14695	18368	22042

EMPTY WEIGHTS

Empty weight	kg	320	385	465	610	725
--------------	----	-----	-----	-----	-----	-----

Note: All the measurements of the connections are considered "from the ground". The thread are female GAS type, unless otherwise specified. The tanks higher than 2200mm are packaged horizontally.

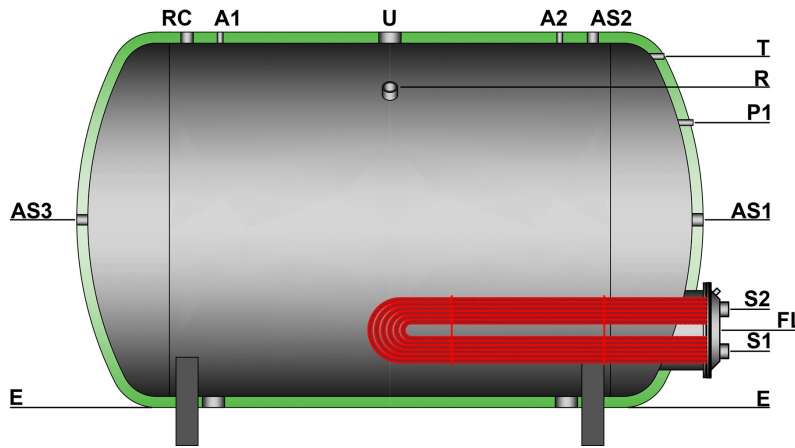

GENERAL CHARACTERISTICS - HORIZONTAL VERSION

	Capacity - L	300	500	800	1000	1500
DIMENSIONS						
Diameter without insulation	mm	550	650	800	800	950
Diameter with insulation	mm	650	750	1000	1000	1150
Overall height	mm	755	855	1091	1091	1254
Overall length	mm	1519	1819	2049	2299	2559

CONNECTIONS

E Cold water supply	mm Ø	105 1 1/2"	105 1 1/2"	121 2"	121 2"	154 2 1/2"
U DHW return	mm Ø	755 1 1/2"	855 1 1/2"	1091 2"	1091 2"	1254 2 1/2"
RC Recirculation	mm Ø	755 1 1/2"	855 1 1/2"	1091 1 1/2"	1091 1 1/4"	1254 1 1/2"
R Immersion electric heater	mm Ø	660 2"	745 2"	945 2"	945 2"	1085 2"
P1 Sensor	mm Ø	548 1/2"	609 1/2"	831 1/2"	831 1/2"	904 1/2"
T Thermometer	mm Ø	655 1/2"	727 1/2"	931 1/2"	931 1/2"	1054 1/2"
A1 Anode	mm Ø	755 1/2"	855 1/2"	1091 1/2"	1091 1/2"	1254 1/2"
A2 Anode	mm Ø	—	—	—	—	1254 1/2"
AS1 Spare	mm Ø	—	—	591 1 1/2"	591 1 1/2"	679 1 1/2"
AS2 Spare	mm Ø	755 1 1/4"	855 1 1/4"	1091 1 1/4"	1091 1 1/4"	1254 1 1/4"
AS3 Spare	mm Ø	430 1 1/4"	480 1 1/4"	591 1 1/4"	591 1 1/4"	679 1 1/4"
FL Heat exchanger manhole	mm Ø	300 220×300	280 220×300	351 300×380	351 300×380	404 300×380
S1 Heat exchanger return	mm Ø	242 1"	221 1"	276 2"	276 2"	329 2"
S2 Heat exchanger supply	mm Ø	359 1"	338 1"	426 2"	426 2"	479 2"

TUBE BUNDLE HEAT EXCHANGERS PERFORMANCES

Heat exchanger heating surface area	m²	0,50	0,75	1,00	1,50	2,00
HEX output (Prim. 6 bar - Sec. 15/60°C)	kW	79	119	159	238	317
DHW continuous flow 15/60°C	L/h	1516	2274	3032	4548	6063
HEX output (Prim. 12 bar - Sec. 15/60°C)	kW	96	144	192	288	384
DHW continuous flow 15/60°C	L/h	1837	2755	3674	5511	7347

EMPTY WEIGHTS

Empty weight	kg	85	120	165	185	245
--------------	----	----	-----	-----	-----	-----

	Capacity - L	2000	2500	3000	4000	5000
DIMENSIONS						
Diameter without insulation	mm	1100	1200	1250	1400	1600
Diameter with insulation	mm	1300	1300	1350	1500	1700
Overall height	mm	1395	1493	1540	1680	1872
Overall length	mm	2587	2590	2804	2907	2947

CONNECTIONS

E Cold water supply	mm Ø	145 2 1/2"	193 3"	190 3"	180 3"	172 3"
U DHW return	mm Ø	1395 2 1/2"	1493 3"	1540 3"	1680 3"	1872 3"
RC Recirculation	mm Ø	1395 1 1/2"	1493 1 1/2"	1540 1 1/2"	1680 1 1/2"	1872 3"
R Immersion electric heater	mm Ø	1204 2"	1303 2"	1342 2"	1459 2"	1619 2"
P1 Sensor	mm Ø	1135 1/2"	1243 1/2"	1190 1/2"	1279 1/2"	1462 1/2"
T Thermometer	mm Ø	1235 1/2"	1343 1/2"	1390 1/2"	1569 1/2"	1762 1/2"
A1 Anode	mm Ø	1395 1/2"	1493 1/2"	1540 1/2"	1680 1/2"	1872 1/2"
A2 Anode	mm Ø	1395 1/2"	1493 1/2"	1540 1/2"	1680 1/2"	1872 1/2"
AS1 Spare	mm Ø	745 1 1/2"	843 1 1/2"	865 1 1/2"	929 1 1/2"	1022 1 1/2"
AS2 Spare	mm Ø	1395 1 1/4"	1493 1 1/4"	1540 1 1/4"	1680 1 1/4"	1872 1 1/4"
AS3 Spare	mm Ø	745 1 1/4"	843 1 1/4"	865 1 1/4"	929 1 1/4"	1022 1 1/4"
FL Heat exchanger manhole	mm Ø	445 300×380	493 300×380	491 300×380	529 350×430	522 350×430
S1 Heat exchanger return	mm Ø	370 2"	418 2"	416 2"	429 2"	422 2"
S2 Heat exchanger supply	mm Ø	520 2"	568 2"	566 2"	629 2"	622 2"

TUBE BUNDLE HEAT EXCHANGERS PERFORMANCES

Heat exchanger heating surface area	m²	2,50	3,00	4,00	5,00	6,00
HEX output (Prim. 6 bar - Sec. 15/60°C)	kW	397	476	635	793	952
DHW continuous flow 15/60°C	L/h	7579	9095	12127	15158	18190
HEX output (Prim. 12 bar - Sec. 15/60°C)	kW	481	577	769	961	1153
DHW continuous flow 15/60°C	L/h	9184	11021	14695	18368	22042

EMPTY WEIGHTS

Empty weight	kg	320	385	465	610	725
--------------	----	-----	-----	-----	-----	-----

Note: All the measurements of the connections are considered "from the ground". The thread are female GAS type, unless otherwise specified. The tanks higher than 2200mm are packaged horizontally.

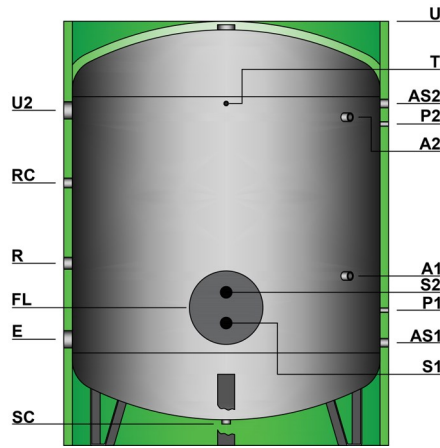

GENERAL CHARACTERISTICS - VERTICAL-LOW VERSION

	Capacity - L	1500	2000	2500	3000	4000	5000
DIMENSIONS							
Diameter without insulation	mm	1100	1250	1400	1400	1600	1800
Diameter with insulation	mm	1300	1450	1500	1500	1700	1900
Overall height	mm	2015	2039	2119	2369	2460	2483
Overturning height with without insulation	mm	2237 2019	2310 2059	2410 2147	2632 2392	2781 2490	2874 2523

CONNECTIONS

E Cold water supply	mm Ø	485 2"½	504 2"½	559 3"	559 3"	620 3"	622 3"
U DHW return	mm Ø	2015 2"½	2039 2"½	2119 3"	2369 3"	2460 3"	2483 3"
U2 Additional DWH return	mm Ø	—	—	1649 3"	1899 3"	1960 3"	1962 3"
RC Recirculation	mm Ø	1235 1"½	1254 1"½	1309 1"½	1474 1"½	1535 1"½	1537 1"½
R Immersion electric heater	mm Ø	865 2"	884 2"	939 2"	1004 2"	1065 2"	1067 2"
P1 Sensor	mm Ø	655 ½"	674 ½"	729 ½"	729 ½"	790 ½"	792 ½"
P2 Sensor	mm Ø	1595 ½"	1564 ½"	1669 ½"	1819 ½"	1880 ½"	1882 ½"
T Thermometer	mm Ø	1595 ½"	1564 ½"	1669 ½"	1939 ½"	2000 ½"	2002 ½"
A1 Anode	mm Ø	870 ½"	864 ½"	944 ½"	929 ½"	990 ½"	992 ½"
A2 Anode	mm Ø	1535 ½"	1504 ½"	1609 ½"	1859 ½"	1920 ½"	1922 ½"
AS1 Spare	mm Ø	465 1"¼	484 1"¼	539 1"¼	539 1"¼	600 1"¼	602 1"¼
AS2 Spare	mm Ø	1265 1"¼	1284 1"¼	1339 1"¼	1939 1"¼	2000 1"¼	2002 1"¼
FL Heat exchanger manhole	mm Ø	655 300×380	674 300×380	729 300×380	729 300×380	790 350×430	792 350×430
S1 Heat exchanger return	mm Ø	580 2"	599 2"	654 2"	654 2"	691 2"	693 2"
S2 Heat exchanger supply	mm Ø	730 2"	749 2"	804 2"	804 2"	891 2"	893 2"
SC Drain	mm Ø	123 1"¼	106 1"¼	114 1"¼	114 1"¼	145 1"¼	126 1"¼

TUBE BUNDLE HEAT EXCHANGERS PERFORMANCES

Heat exchanger heating surface area	m²	2,00	2,50	3,00	4,00	5,00	6,00
HEX output (Prim. 6 bar - Sec. 15/60°C)	kW	317	397	476	635	793	952
DHW continuous flow 15/60°C	L/h	6063	7579	9095	12127	15158	18190
HEX output (Prim. 12 bar - Sec. 15/60°C)	kW	384	481	577	769	961	1153
DHW continuous flow 15/60°C	L/h	7347	9184	11021	14695	18368	22042

EMPTY WEIGHTS

Empty weight	kg	260	335	440	480	585	750
--------------	----	-----	-----	-----	-----	-----	-----

Note: All the measurements of the connections are considered "from the ground". The thread are female GAS type, unless otherwise specified. The tanks higher than 2200mm are packaged horizontally.

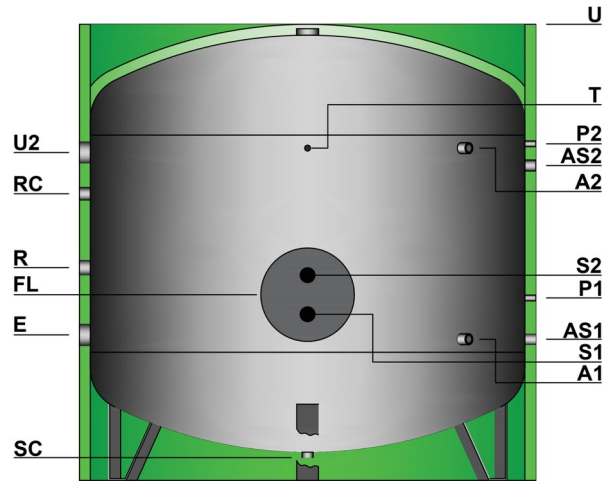

GENERAL CHARACTERISTICS - VERTICAL EXTRA-LOW VERSION

	Capacity - L	3000	4000	5000
DIMENSIONS				
Diameter without insulation	mm	1500	1700	2000
Diameter with insulation	mm	1600	1800	2100
Overall height	mm	2130	2190	2100
Overturning height with without insulation	mm	2452 2161	2579 2230	2628 2160

CONNECTIONS					
E	Cold water supply	mm Ø	560 3"	590 3"	670 3"
U	DHW return	mm Ø	2130 3"	2190 3"	2100 3"
U2	Additional DWH return	mm Ø	1650 3"	1680 3"	1510 3"
RC	Recirculation	mm Ø	1340 1"½	1370 1"½	1320 1"½
R	Immersion electric heater	mm Ø	1030 2"	1060 2"	980 2"
P1	Sensor	mm Ø	730 ½"	760 ½"	840 ½"
P2	Sensor	mm Ø	1670 ½"	1700 ½"	1530 ½"
T	Thermometer	mm Ø	1670 ½"	1700 ½"	1530 ½"
A1	Anode	mm Ø	540 ½"	570 ½"	650 ½"
A2	Anode	mm Ø	1590 ½"	1620 ½"	1530 ½"
AS1	Spare	mm Ø	540 1"¼	570 1"¼	650 1"¼
AS2	Spare	mm Ø	1340 1"¼	1370 1"¼	1450 1"¼
FL	Heat exchanger manhole	mm Ø	730 350×430	760 350×430	840 350×430
S1	Tube bundle heat exchanger return	mm Ø	655 2"	661 2"	741 2"
S2	Tube bundle heat exchanger supply	mm Ø	805 2"	861 2"	941 2"
SC	Drain	mm Ø	105 1"¼	105 1"¼	105 1"¼

TUBE BUNDLE HEAT EXCHANGERS PERFORMANCES					
Heat exchanger heating surface area		m²	4,00	5,00	6,00
HEX output (Prim. 6 bar - Sec. 15/60°C)		kW	635	793	952
DHW continuous flow 15/60°C		L/h	12127	15158	18190
HEX output (Prim. 12 bar - Sec. 15/60°C)		kW	769	961	1153
DHW continuous flow 15/60°C		L/h	14695	18368	22042

EMPTY WEIGHTS					
Empty weight		kg	480	630	740

Note: All the measurements of the connections are considered "from the ground". The thread are female GAS type, unless otherwise specified. The tanks higher than 2200mm are packaged horizontally.

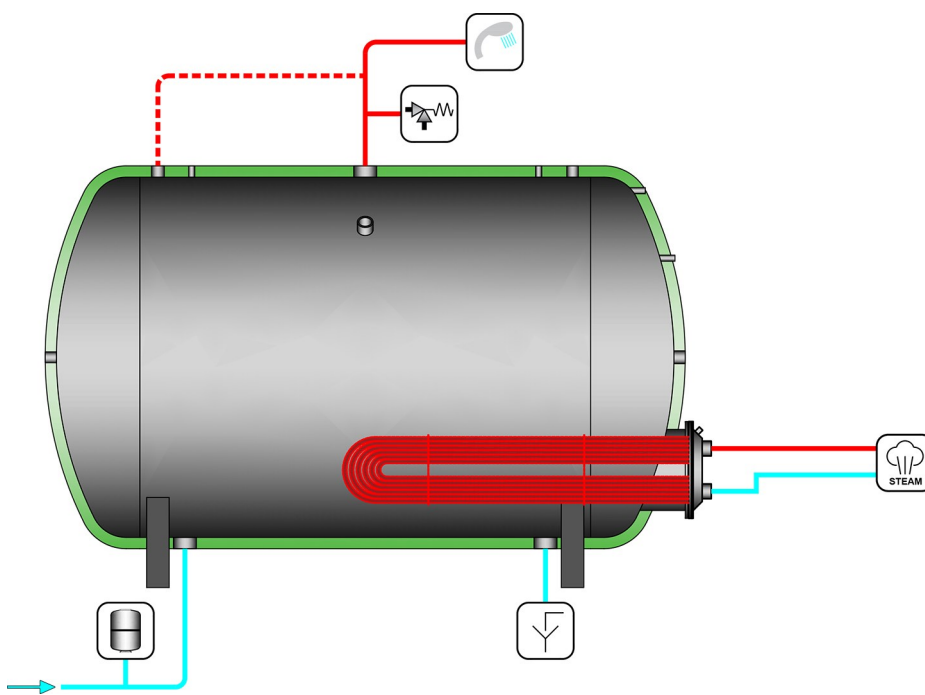
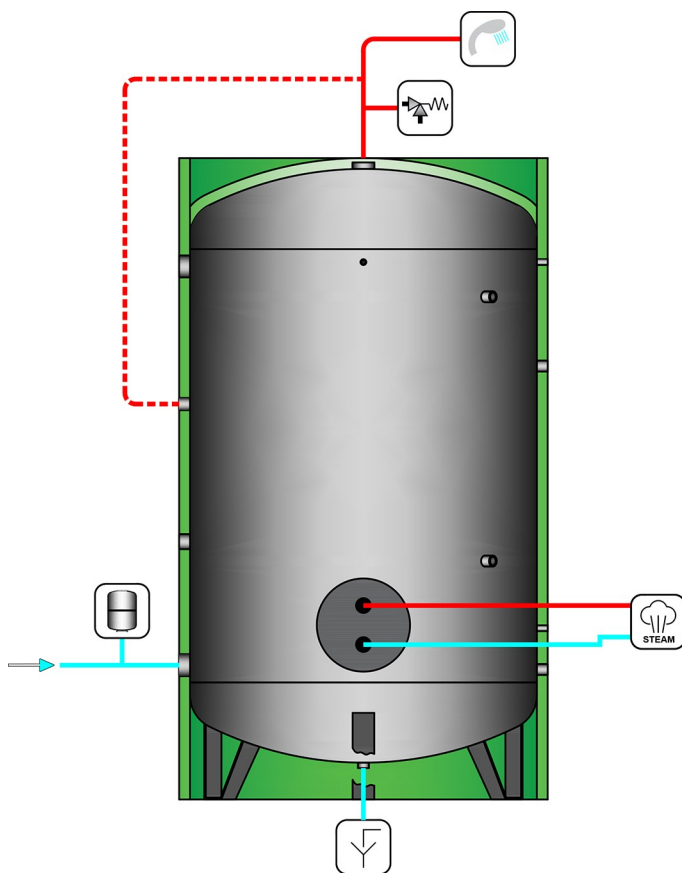

The proposed diagrams are for illustration purposes only.

TUBE BUNDLE HEAT EXCHANGER OUTPUT - STEAM PRIMARY UP TO 6 BAR

STEAM primary 111,6°C (0,5 bar) | secondary (15-60)°C

SECONDARY (DHW)

Storage Volume	Heating surface area	Capacity	Continuos production	First 10' production	First 60' production
<i>L</i>	<i>m²</i>	<i>kW</i>	<i>L/h</i>	<i>L</i>	<i>L</i>
300	0,50	46	881	447	1181
500	0,75	69	1321	720	1821
800	1,00	92	1762	1094	2562
1000	1,50	138	2643	1440	3643
1500	2,00	184	3524	2087	5024
2000	2,50	230	4405	2734	6405
2500	3,00	276	5286	3381	7786
3000	4,00	368	7048	4175	10048
4000	5,00	461	8810	5468	12810
5000	6,00	553	10572	6762	15572

STEAM primary 120,4°C (1 bar) | secondary (15-60)°C

SECONDARY (DHW)

Storage Volume	Heating surface area	Capacity	Continuos production	First 10' production	First 60' production
<i>L</i>	<i>m²</i>	<i>kW</i>	<i>L/h</i>	<i>L</i>	<i>L</i>
300	0,50	51	986	464	1286
500	0,75	77	1478	746	1978
800	1,00	103	1971	1129	2771
1000	1,50	154	2957	1493	3957
1500	2,00	206	3942	2157	5442
2000	2,50	258	4928	2821	6928
2500	3,00	309	5914	3486	8414
3000	4,00	413	7885	4314	10885
4000	5,00	515	9856	5643	13856
5000	6,00	619	11827	6971	16827

STEAM primary 133,7°C (2 bar) | secondary (15-60)°C

SECONDARY (DHW)

Storage Volume	Heating surface area	Capacity	Continuos production	First 10' production	First 60' production
<i>L</i>	<i>m²</i>	<i>kW</i>	<i>L/h</i>	<i>L</i>	<i>L</i>
300	0,50	60	1144	491	1444
500	0,75	90	1716	786	2216
800	1,00	120	2287	1181	3087
1000	1,50	180	3431	1572	4431
1500	2,00	239	4575	2262	6075
2000	2,50	300	5719	2953	7719
2500	3,00	359	6862	3644	9362
3000	4,00	479	9150	4525	12150
4000	5,00	598	11437	5906	15437
5000	6,00	718	13725	7287	18725

STEAM primary 142,5°C (3 bar) | secondary (15-60)°C

SECONDARY (DHW)

Storage Volume	Heating surface area	Capacity	Continuos production	First 10' production	First 60' production
<i>L</i>	<i>m²</i>	<i>kW</i>	<i>L/h</i>	<i>L</i>	<i>L</i>
300	0,50	65	1248	508	1548
500	0,75	98	1873	812	2373
800	1,00	131	2497	1216	3297
1000	1,50	196	3745	1624	4745
1500	2,00	261	4993	2332	6493
2000	2,50	326	6242	3040	8242
2500	3,00	392	7490	3748	9990
3000	4,00	523	9987	4664	12987
4000	5,00	653	12483	6081	16483
5000	6,00	784	14980	7497	19980

GALVANISED STEEL DHW CALORIFIER WITH ONE REMOVABLE HEAT EXCHANGER FOR STEAM OR OVERHEATED WATER PRIMARY

TUBE BUNDLE HEAT EXCHANGER OUTPUT - STEAM PRIMARY UP TO 6 BAR

STEAM primary 152,0°C (4 bar) | secondary (15-60)°C

Storage Volume	Heating surface area	Capacity	Continuos production	SECONDARY (DHW)	
				First 10' production	First 60' production
<i>L</i>	<i>m²</i>	<i>kW</i>	<i>L/h</i>	<i>L</i>	<i>L</i>
300	0,50	71	1361	527	1661
500	0,75	107	2042	840	2542
800	1,00	142	2723	1254	3523
1000	1,50	214	4084	1681	5084
1500	2,00	285	5445	2408	6945
2000	2,50	356	6806	3134	8806
2500	3,00	427	8168	3861	10668
3000	4,00	570	10890	4815	13890
4000	5,00	712	13613	6269	17613
5000	6,00	855	16335	7723	21335

STEAM primary 159,0°C (5 bar) | secondary (15-60)°C

Storage Volume	Heating surface area	Capacity	Continuos production	SECONDARY (DHW)	
				First 10' production	First 60' production
<i>L</i>	<i>m²</i>	<i>kW</i>	<i>L/h</i>	<i>L</i>	<i>L</i>
300	0,50	75	1439	540	1739
500	0,75	113	2158	860	2658
800	1,00	151	2877	1280	3677
1000	1,50	226	4316	1719	5316
1500	2,00	301	5754	2459	7254
2000	2,50	376	7193	3199	9193
2500	3,00	452	8631	3939	11131
3000	4,00	602	11508	4918	14508
4000	5,00	753	14386	6398	18386
5000	6,00	903	17263	7877	22263

STEAM primary 165,0°C (6 bar) | secondary (15-60)°C

Storage Volume	Heating surface area	Capacity	Continuos production	SECONDARY (DHW)	
				First 10' production	First 60' production
<i>L</i>	<i>m²</i>	<i>kW</i>	<i>L/h</i>	<i>L</i>	<i>L</i>
300	0,50	79	1516	553	1816
500	0,75	119	2274	879	2774
800	1,00	159	3032	1305	3832
1000	1,50	238	4548	1758	5548
1500	2,00	317	6063	2511	7563
2000	2,50	397	7579	3263	9579
2500	3,00	476	9095	4016	11595
3000	4,00	635	12127	5021	15127
4000	5,00	793	15158	6526	19158
5000	6,00	952	18190	8032	23190

NOTE: Performance is reduced by 10% with overheated water primary.

BTWH-Z - BTV-Z



R02-26

TUBE BUNDLE HEAT EXCHANGER OUTPUT - STEAM PRIMARY UP TO 12 BAR

STEAM primary 170,0°C (7 bar) | secondary (15-60)°C

SECONDARY (DHW)

Storage Volume	Heating surface area	Capacity	Continuos production	First 10' production	First 60' production
<i>L</i>	<i>m²</i>	<i>kW</i>	<i>L/h</i>	<i>L</i>	<i>L</i>
300	0,50	82	1575	563	1875
500	0,75	124	2363	894	2863
800	1,00	165	3151	1325	3951
1000	1,50	247	4726	1788	5726
1500	2,00	330	6301	2550	7801
2000	2,50	412	7876	3313	9876
2500	3,00	495	9452	4075	11952
3000	4,00	659	12602	5100	15602
4000	5,00	824	15753	6625	19753
5000	6,00	989	18903	8151	23903

STEAM primary 175,4°C (8 bar) | secondary (15-60)°C

SECONDARY (DHW)

Storage Volume	Heating surface area	Capacity	Continuos production	First 10' production	First 60' production
<i>L</i>	<i>m²</i>	<i>kW</i>	<i>L/h</i>	<i>L</i>	<i>L</i>
300	0,50	86	1639	573	1939
500	0,75	129	2459	910	2959
800	1,00	172	3279	1346	4079
1000	1,50	257	4918	1820	5918
1500	2,00	343	6558	2593	8058
2000	2,50	429	8197	3366	10197
2500	3,00	515	9837	4139	12337
3000	4,00	686	13116	5186	16116
4000	5,00	858	16395	6732	20395
5000	6,00	1029	19674	8279	24674

STEAM primary 180,0°C (9 bar) | secondary (15-60)°C

SECONDARY (DHW)

Storage Volume	Heating surface area	Capacity	Continuos production	First 10' production	First 60' production
<i>L</i>	<i>m²</i>	<i>kW</i>	<i>L/h</i>	<i>L</i>	<i>L</i>
300	0,50	89	1694	582	1994
500	0,75	133	2541	924	3041
800	1,00	177	3388	1365	4188
1000	1,50	266	5083	1847	6083
1500	2,00	355	6777	2629	8277
2000	2,50	443	8471	3412	10471
2500	3,00	532	10165	4194	12665
3000	4,00	709	13553	5259	16553
4000	5,00	886	16942	6824	20942
5000	6,00	1064	20330	8388	25330

STEAM primary 184,0°C (10 bar) | secondary (15-60)°C

SECONDARY (DHW)

Storage Volume	Heating surface area	Capacity	Continuos production	First 10' production	First 60' production
<i>L</i>	<i>m²</i>	<i>kW</i>	<i>L/h</i>	<i>L</i>	<i>L</i>
300	0,50	91	1742	590	2042
500	0,75	137	2613	935	3113
800	1,00	182	3483	1381	4283
1000	1,50	273	5225	1871	6225
1500	2,00	365	6967	2661	8467
2000	2,50	456	8709	3451	10709
2500	3,00	547	10450	4242	12950
3000	4,00	729	13934	5322	16934
4000	5,00	911	17417	6903	21417
5000	6,00	1094	20901	8483	25901

GALVANISED STEEL DHW CALORIFIER WITH ONE REMOVABLE HEAT EXCHANGER FOR STEAM OR OVERHEATED WATER PRIMARY

TUBE BUNDLE HEAT EXCHANGER OUTPUT - STEAM PRIMARY UP TO 12 BAR

STEAM primary 188,0°C (11 bar) | secondary (15-60)°C

Storage Volume	Heating surface area	Capacity	Continuos production	SECONDARY (DHW)	
				First 10' production	First 60' production
<i>L</i>	<i>m²</i>	<i>kW</i>	<i>L/h</i>	<i>L</i>	<i>L</i>
300	0,50	94	1789	598	2089
500	0,75	140	2684	947	3184
800	1,00	187	3579	1396	4379
1000	1,50	281	5368	1895	6368
1500	2,00	375	7157	2693	8657
2000	2,50	468	8946	3491	10946
2500	3,00	562	10736	4289	13236
3000	4,00	749	14314	5386	17314
4000	5,00	936	17893	6982	21893
5000	6,00	1124	21471	8579	26471

STEAM primary 192,0°C (12 bar) | secondary (15-60)°C

Storage Volume	Heating surface area	Capacity	Continuos production	SECONDARY (DHW)	
				First 10' production	First 60' production
<i>L</i>	<i>m²</i>	<i>kW</i>	<i>L/h</i>	<i>L</i>	<i>L</i>
300	0,50	96	1837	606	2137
500	0,75	144	2755	959	3255
800	1,00	192	3674	1412	4474
1000	1,50	288	5511	1918	6511
1500	2,00	384	7347	2725	8847
2000	2,50	481	9184	3531	11184
2500	3,00	577	11021	4337	13521
3000	4,00	769	14695	5449	17695
4000	5,00	961	18368	7061	22368
5000	6,00	1153	22042	8674	27042

NOTE: Performance is reduced by 10% with overheated water primary.

HOW TO ORDER

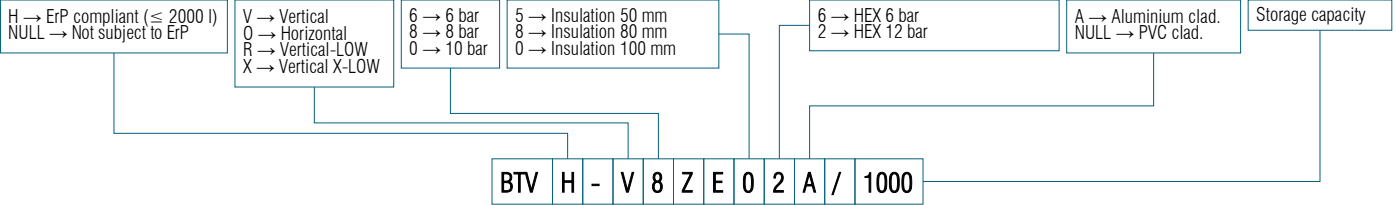

ACCESSORIES & SPARE PARTS

ITEM

	PART NO.		
THERMOMETER Ø65 mm L=150 mm (0÷120)°C	TERMOMETRO-D65_L		THERMOMETER
THERMOMETER Ø100 mm L=150 mm (0÷120)°C	TERMOMETRO-D100		
SENSOR SOCKET Ø½" L=150 mm Ø _{int} 10 mm	POZZETTO_L		SENSOR SOCKET
THERMOSTAT Ø½" (0÷90)°C	TERMOSTATO		THERMOSTAT
ELECTRONIC ANODE KIT 300÷500 L	ANODE012X380_P		
ELECTRONIC ANODE KIT 800-1000 L	ANODE012X430_P		
ELECTRONIC ANODE KIT 1500÷5000 L	ANODE012X430X2_P		ELECTRONIC ANODE

1-PHASE & 3-PHASE IMMERSION ELECTRIC HEATER - STAINLESS STEEL 316L TUBES
Threaded plug 1.1/2" with brass adapter 1.1/2" to 2" | Aluminium box IP54 | V220/1-V240/1 or V400/3

Capacity	Capacity/L matching	Length	Volt	Plug type	2-THERMOSTAT Temperature regulation & overheating protection	
Watt	L	mm	mm	mm	PART NO.	
2000	300 ÷ 5000	310	220/1	SHUKO	RES020-L310-6-M-BT	
3000	300 ÷ 5000	350	240/1		RES030-L350-6-M-BT	
5000	300 ÷ 5000	375	400/3	Not supplied	RES050-L375-6-T-BT	
6000	300 ÷ 5000	435			RES060-L435-6-T-BT	
9000	500 ÷ 5000	610			RES090-L610-6-T-BT	
10000	500 ÷ 5000	670			RES100-L670-6-T-BT	
12000	800 ÷ 5000	730			RES120-L727-6-T-BT	
15000	1500 ÷ 5000	870			RES150-L870-6-T-BT	

Sealing GASKETS

Diameter Internal×External	Capacity	SILICONE gasket with cross bar	SILICONE gasket without cross bar	GRAPHITE gasket with cross bar	GRAPHITE gasket without cross bar
mm	L	Primary up to 6 bar	Primary up to 6 bar	Primary up to 12 bar	Primary up to 12 bar
		Part no.	Part no.	Part no.	Part no.
220×300	300 ÷ 500	GUSIL300X220CT	GUSIL300X220ST	GUGRA300X220CT	GUGRA300X220ST
300×380	800 ÷ 3000	GUSIL380X300CT	GUSIL380X300ST	GUGRA380X300CT	GUGRA380X300ST
350×430	4000-5000	GUSIL430X350CT	GUSIL430X350ST	GUGRA430X350CT	GUGRA430X350ST

TUBE BUNDLE HEAT EXCHANGERS FOR STEAM OR OVERHEATED WATER PRIMARY

Heating surface area	Dimensions		PRIMARY UP TO 6 BAR		PRIMARY UP TO 12 BAR	
	D	L	PED Category	Tubes & tubeplate in Stainless steel AISI 316L Galvanized primary chest	PED Category	Tubes & tubeplate in Stainless steel AISI 316L Galvanized primary chest
m ²	mm	mm		Part no.		Part no.
0,50	300	445	art. 4.3	SFX6005D300-Z-1.5V	art. 4.3	SFX6005D300-Z-1.5V-12BAR
0,75	300	445		SFX6007D300-Z-1.5V		SFX6007D300-Z-1.5V-12BAR
1,00	380	476		SFX6010D380-Z-1.5V		SFV6Z_380X-10-12BAR
1,50	380	594		SFX6015D380-Z-1.5V		SFV6Z_380X-15-12BAR
2,00	380	594	Cat. I	SFV6Z_380X-20	Cat. I	SFV6Z_380X-20-12BAR
2,50	380	594		SFV6Z_380X-25		SFV6Z_380X-25-12BAR
3,00	380	718		SFV6Z_380X-30		SFV6Z_380X-30-12BAR
4,00	380	850		SFV6Z_380X-40		SFV6Z_380X-40-12BAR
5,00	430	785		SFV6Z_430X-50		SFV6Z_430X-50-12BAR
6,00	430	895		SFV6Z_430X-60		SFV6Z_430X-60-12BAR

This page is left intentionally blank.

PROTECTIVE TREATMENTS FOR CARBON STEEL TANKS

Hot dip galvanising

The corrosion treatment by hot dip galvanising in accordance with UNI EN ISO 1461 is carried out by immersion of the chemically pickled tank in a bath of molten zinc at a temperature of approximately 450°C.

CATHODIC PROTECTION

The corrosion of a metal structure occurs mainly in areas in which there is the passage of current (oxidation-reduction process) from the structure towards the outside (water or gas) causing a dissolution of the structure itself.

Cathodic protection by means of magnesium anodes.

The application of sacrificial magnesium anodes is a simple and economic method to obtain a cathodic protection. The sacrificial anode creates a situation similar to an electric battery, where the electrodes are represented by the anode and the metal structure to be protected.

Since the magnesium has a dissolution voltage which is much higher than that of other metals, the corrosion will only affect the anode, which will dissolve slowly, to the advantage of the metal structure to be protected.

Given the importance of the protection of the metal against corrosion, the wear of the anode is systematically controlled and it is immediately replaced if consumed.



Cathodic protection by means of electronic impressed current system.

As an alternative to the galvanic system (coupling of materials with different potentials) there is a protection method which consists in applying an equal and opposite continuous current to the metallic structure to be protected, neutralising the voltages formed inside the tank.

Thanks to the modern techniques there is an innovative electronic system of cathodic protection with continuous impressed current.

The main advantages are:

- active protection by means of impressed currents from the outside;
- excellent flexibility of operation in order to adhere to the changeable internal coating conditions and the mass of water;
- reduction of maintenance costs due to the permanent protection of the system.



INSULATIONS

Insulating material	Removable	Thickness	Density	Thermal conductivity coefficient at 45°C	Operating temperature	Fire reaction class Euroclass EN13501-1
PLF Polyester fibre	✓	50 mm	20 kg/m ³	$\lambda = 0,037 \text{ W/mK}$	Amb. / +99°C	B-s2, d0
PLFH High density polyester fibre	✓	100 mm	25 kg/m ³	$\lambda = 0,034 \text{ W/mK}$	Amb. / +99°C	B-s2, d0
Hard foam polyurethane	✗	80 mm	40 ÷ 42 kg/m ³	$\lambda = 0,019 \text{ W/mK}$	-10°C / +99°C	F

PLFH / PLF – Polyester fibre

- 100% recyclable
- Environmental friendly
- Lightweight
- Self-supporting
- Fire-retardant
- Rot-proof
- Resistant to mould, bacteria or rodents
- Hypoallergenic
- Water repellent



The raw materials consist of polyester fibres and heat-bonded co-polyester fibres, coming mainly from the recycling of plastic bottles obtained from urban waste collection.

It does not contain substances harmful to humans, may be handled and installed in complete safety, does not release powder, is hypoallergenic and cannot be attacked by microorganisms, mould and insects.

PLFH/PLF is a heat insulating product considered environmentally sustainable, even though it is not of natural origin: it is in fact recyclable and the quantity of embodied energy necessary to obtain it is extremely low.

The composition of the polyester fibre makes it an insulating material with an extremely low heat dispersion and its characteristics remain unaltered over time as it is not affected by humidity and its compact, flexible and resistant original structure is not modified.

Thanks to its characteristics, PLFH/PLF is an insulating material with the highest performance characteristics, which allows the requirements set by the severest technical standards to be satisfied, guaranteeing the maximum environmental compatibility for its entire life cycle.

Hard foam Polyurethane

Thermal and anti-condensation insulation made of hard closed cell polyurethane foam (PU), free from CFC and HCFC.

It is available in various thickness and can be injected directly to the shell of the tank to prevent it from condensation and provide the lower thermal dispersion. For some sizes it is pre-formed into half-shells to ease the insulation removal in case the tank has to pass through narrow doors.

CLADDINGS



PVC

External cladding made of coloured PVC with hinge closing, suitable for installations in locations protected against adverse weather conditions. The standard colours of each product are indicated in their construction characteristics,

but different colours can be requested for each model as shown in the following table.

In the personalised TLR storage tanks the choice of the alternative colour is free of cost and does not incur any surcharge.

ITEM

PART NUMBER

PVC COVER YELLOW RAL1023	COVER-RAL1023
PVC COVER ORANGE RAL2004	COVER-RAL2004
PVC COVER RED RAL3000	COVER-RAL3000
PVC COVER BLUE RAL5015	COVER-RAL5015
PVC COVER WHITE RAL9016	COVER-RAL9016
PVC COVER LIGHT GREY RAL7035	COVER-RAL7035
PVC COVER DARK GREY RAL7024	COVER-RAL7024
PVC COVER BLACK RAL9004	COVER-RAL9004



ALUMINIUM

External cladding made of embossed aluminium sheeting suitable also for outdoor installations. The insulations made with this type of cladding consist of panels joined together by means of rivets and extruded aluminium slats

with an exclusive design, specifically designed to facilitate assembly even directly at the installation site.

The coverings and flange covers made of same material securely anchored to the insulation guarantee the same levels of quality in terms of duration and outside appearance and do not risk being damaged by the wind and adverse weather conditions.

www.pacetti.it



MADE IN ITALY

PACETTI S.r.l.

Via G. Marconi, 240/242

44122 - Ferrara - ITALY

Tel. +39 0532 774066

Fax +39 0532 773835

info@pacetti.it